

Exhibit A ³⁻²⁰
Design Review of FPD 1-20
Officially Approved by
Planning Commission
Date Sept 9/Sept 23, 2020
Officially Approved
by City Council
Date N/A
Shawn Metzger NOV 13, 2020
Authorized Signature & Date

*This copy has language
as amended by the Plg. Comm.*



Bretton Woods

DESIGN GUIDELINES & FINAL PLANNED DEVELOPMENT

Revised October 19, 2020

CONTENTS

CHAPTER 1: DESIGN REVIEW

1.1. Purpose	pg. 3
1.2. Document Authority	pg. 3
1.3. Administration Overview	pg. 3
1.3.1. Compliance	pg. 3
1.3.2. Conflicts with City Code	pg. 3
1.3.3. Deviations and Amendments	pg. 3
1.4. Residential Design Review Process	pg. 4

CHAPTER 2: NEIGHBORHOOD FRAMEWORK

2.1. Location and Setting	pg. 6
2.2. Guiding Principles	pg. 7
2.3. Livable Design Principles	pg. 8
2.4. Site Plan	pg. 9
2.5. Community Connectivity	pg. 10
2.5.1. West Covell Boulevard	pg. 10
2.5.2. North/South Pedestrian Path	pg. 11
2.5.3. Arboretum, Art and Poetry Trail	pg. 11
2.5.4. Oak Forest	pg. 11
2.5.5. Art Nodes	pg. 11
2.6. Parks and Community Space	pg. 12
2.6.1. Sycamore Grove	pg. 12
2.6.2. Pocket Park	pg. 12
2.6.3. Vista Park	pg. 12
2.6.4. Dog Park	pg. 13
2.6.5. Community Gathering Park	pg. 13
2.6.6. Activity and Wellness Center (Grounds)	pg. 13

CHAPTER 3: LANDSCAPE DESIGN

3.1. Introduction	pg. 14
3.2. Residential Connectivity	pg. 15
3.2.1. Greenway Homes	pg. 15
3.2.2. Single-Loaded Greenway Homes	pg. 16
3.3. Planting Design Principles	pg. 17
3.3.1. Overall Planting Guidelines	pg. 17
3.3.2. On-Site Residential Landscape	pg. 17
3.3.3. Agricultural Buffer	pg. 17

3.3.4. Irrigation and Water Conservation	pg. 17
3.3.5. Drought Tolerant Landscape	pg. 17
3.3.6. Master Builder Series Lot Design	pg. 18
3.3.7. Custom Home Lot Design	pg. 19
3.4. Site Furnishings and Materials	pg. 20
3.4.1. Lighting	pg. 20
3.4.2. Signage	pg. 20
3.4.3. Site Furniture	pg. 20
3.4.4. Fences and Gates	pg. 20
3.4.5. Paving and Hardscape	pg. 20
3.4.6. Ancillary Structures	pg. 20

CHAPTER 4: DESIGN GUIDELINES - MASTER BUILDER SERIES

4.1. Master Builder Series Design Principles	pg. 21
4.1.1. Streetscape Diversity	pg. 21
4.1.2. Home Types and Sizes	pg. 21
4.1.3. Exterior Lighting at Dwelling	pg. 22
4.1.4. Address Signage	pg. 23
4.2. Cottage Homes	pg. 24
4.2.1. Elevations and Floor Plans: Example 1	pg. 24
4.3. Bungalow Homes	pg. 25
4.3.1. Elevations and Floor Plans: Example 1	pg. 25
4.3.2. Elevations and Floor Plans: Example 2	pg. 26
4.4. Greenway Homes	pg. 27
4.4.1. Elevations and Floor Plans: Example 1	pg. 27
4.4.2. Elevations and Floor Plans: Example 2	pg. 29
4.4.3. Elevations and Floor Plans: Example 3	pg. 31

CHAPTER 5: DESIGN GUIDELINES - CUSTOM HOMES

5.1. Custom Home Design Principles	pg. 33
5.1.1. Overview	pg. 33
5.1.2. Home Types and Sizes	pg. 33
5.2. Custom Home Design Guidelines	pg. 34
5.2.1. Exterior Lighting at Dwelling	pg. 35
5.2.2. Address Signage	pg. 36
5.3. Materials and Treatments	pg. 37

5.3.1. Overall Design	pg. 37
5.3.2. Building Materials	pg. 38
5.3.3. Exterior Structure Materials	pg. 39
5.3.4. Exterior Structure Treatments	pg. 40
5.3.5. Element Materials and Configurations	pg. 41

CHAPTER 6: FINAL PLANNED DEVELOPMENT

6.1. Final Planned Development Table	pg. 42
6.2. Single Family Home Lot Setback Diagrams	pg. 43
6.3. Senior Affordable Apartments	pg. 45
6.1.1. Unit Types and Sizes	pg. 45
6.1.2. Setbacks	pg. 45
6.4. Specialized Senior Care	pg. 46
6.2.1. Setbacks	pg. 46

APPENDIX A

References and Contact Information	pg. 47
------------------------------------	--------

APPENDIX B

Planting Palette	pg. 48
B.1. Trees	pg. 48
B.2. Oak Forest	pg. 48
B.3. Fruit Trees for Front Yards at Greenways	pg. 49
B.4. Groundcovers	pg. 49
B.5. Ornamental Grasses	pg. 49
B.6. Shrubs - Large	pg. 50
B.7. Shrubs - Medium	pg. 50
B.8. Shrubs - Small	pg. 51
B.9. Vines	pg. 52
B.10. Roses	pg. 52
B.11. Ground Plane	pg. 52

CHAPTER 1: DESIGN REVIEW

1.1. PURPOSE

The purpose of this document is to work in concert with the Rezoning/Preliminary Planned Development Zoning Ordinance adopted for the property, consistent with Article 40.22 PLANNED DEVELOPMENT (P-D) DISTRICT of Chapter 40 of the City of Davis Municipal Code, to guide the planning and design of the Plan Area. These Guidelines provide a comprehensive overview of the design criteria and development standards required to implement the desired physical form of the community and its key features. The Guidelines address land use, site design, sustainability, architecture, landscaping, circulation, and other components to create a distinguished community comprised of high quality architecture, ample open space and recreational areas, and a balanced mixture of uses. These Guidelines function to:

- (1) Implement the City of Davis General Plan goals for the Plan Area;
- (2) Establish a design framework within which developers, builders, and architects/designers can conceive and produce high-quality design and construction within the development; and
- (3) Create a design review framework by which to evaluate, critique, and approve development projects on individual sites within the Plan Area.

These Guidelines will be used in conjunction with the Rezoning/Preliminary Planned Development Zoning Ordinance adopted for the property, to supplement and replace zoning standards for the property, which would otherwise apply under Chapter 40 of the City of Davis Municipal Code. In addition, these Guidelines provide written and graphic descriptions of planning and design concepts based on smart growth and environmentally responsible design solutions.

1.2. DOCUMENT AUTHORITY

The Plan Area consists of property within the City limits of the City of Davis and is subject to the land use and jurisdictional authority of the City's relevant ordinances and codes. Adoption of these Guidelines is subject to the California Environmental Quality Act (CEQA) and requires consistency with the City's General Plan. The General Plan provides the overall guidance for the City's physical development by setting forth general goals, objectives, policies, and programs for the entire City planning area. The Rezoning/Preliminary Planned Development Zoning Ordinance adopted for the property, consistent with Article 40.22 PLANNED DEVELOPMENT (P-D) DISTRICT of Chapter 40 of the City of Davis Municipal Code, along with these Guidelines, implement the City General Plan with specific development standards and design guidelines for the Plan Area, governing individual project applications and construction. This set of guidelines establishes a link between the General Plan and future individual project level development proposals.

1.3. ADMINISTRATION OVERVIEW

1.3.1. COMPLIANCE

This project, as a Planned Development, and its associated Rezoning/Preliminary Planned Development Zoning Ordinance for the property, as approved and adopted by the Davis City Council, will serve as a supplement to the existing Davis Zoning Code for the Plan Area. The City Planning Staff, Planning Commission, and City Council will use these Development Guidelines as a vehicle to review specific development proposals and to implement the project's vision and regulations. Future development proposals and plans, whether individual buildings or collectively phased projects, must comply with these Guidelines, as well as the General Plan and Zoning Code, where applicable. These Development Guidelines are intended to be used by City staff, property owners, architects, landscape architects, designers, builders, and developers in the planning and design of individual projects within the Plan Area.

1.3.2. CONFLICTS WITH CITY CODE

Should particular elements in these Guidelines or the Rezoning/Preliminary Planned Development Zoning Ordinance adopted for the property conflict with development standards or regulations in the Davis Zoning Code, the Final Planned Development shall prevail. Conversely, any particular element or provision not specifically covered in the Final Planned Development or these Guidelines shall be subject to the provisions of the Davis Zoning Code.

1.3.3. DEVIATIONS AND AMENDMENTS

Deviations to these standards may be considered for projects with special unique and design characteristics during the BWDRC process and the City's development review process. This document is intended to encourage and direct a high level of design quality to the project site while permitting flexibility for creative expression and innovative design solutions.

Deviations can be classified as Minor Deviations and Major Deviations. This document grants the Community Development Director the authority to determine whether a deviation should be considered Minor or Major. Review and approval of Minor Deviations shall be conducted by the Community Development Director, whereas Major Deviations shall be reviewed and approved by Planning Commission.

Amendments to these Final Planned Development standards as established in the Bretton Woods Neighborhood Design Guidelines shall be reviewed and approved by the Planning Commission. All site plan, architectural, open space and fencing changes shall be reviewed for approval by the Community Development and Sustainability Department.

CHAPTER 1: DESIGN REVIEW

1.4. RESIDENTIAL DESIGN REVIEW PROCESS

The design review process described in this section is intended to ensure that residential projects developed for Bretton Woods contribute to the character and quality envisioned for the neighborhood. This three-step process is intended to be efficient, without compromising the quality of design solutions. The Bretton Woods Architectural Review Committee (BWARC), comprised of representatives of the master developer and design professionals appointed by the master developer, will review all residential designs developed for the Bretton Woods neighborhood prior to submittal to the city.

STEP 1: PROJECT APPLICATION

The design review process will commence upon receipt of the Homeowner's / Builder's application form and review fee. At the applicant's discretion, a kick-off and orientation meeting with the BWARC is suggested.

SUBMITTAL REQUIREMENTS:

1. Completed application form and fee

STEP 2: PRELIMINARY DESIGN REVIEW

This step is intended to establish and define the project's preliminary architectural and landscape character and concepts. Upon review and approval of the Homeowner's / Builder's submittal package, the BWARC will schedule a Preliminary Design Review Session, during which the BWARC will meet with the Homeowner / Builder to review and discuss the submittal.

The Preliminary Design Review Session is an opportunity to review the following design criteria:

- Selected primary and secondary architectural styles from Bretton Woods Architectural Palette.
- Architectural form, massing, roofs, and details, which establish character.
- Preliminary thoughts on colors and materials.
- Landscape concepts identifying major tree and shrub massing, hardscape areas and proposed character.

Following the Preliminary Design Review, the BWARC shall prepare and submit to the applicant, within 15 business days of plan submittal, a written memorandum outlining the agreed-upon direction of the BWARC and the applicant.

SUBMITTAL REQUIREMENTS:

CIVIL / PLANNING

1. Location map showing project location within the overall neighborhood.

LANDSCAPE

2. Landscape concept plans, identifying general planting scheme, street tree program, front, side, and rear yards (if applicable). Plans shall be prepared at a minimum scale of 1"=20'.
3. Color illustrative depicting typical landscape treatment for at least three contiguous lots, including one corner lot. The typical plan shall include at least one of each floor plan proposed for the project. The plan shall include a description of the landscape concept.

ARCHITECTURE

4. Preliminary building floor plans and front elevations. These should be at minimum 1/4"=1'-0" scale.
5. Building coverage or floor area ratio calculations.
6. Consistency with project development standards and architectural guidelines.

The BWARC will issue a Preliminary Design Review Memorandum (PDRM) detailing the results of the Preliminary Design Review. The PDRM will state one of the following:

1. Approved to move forward to Final Design Review
2. Approved to move forward to Final Design Review with Comments & Conditions
3. Denied with Comments; resubmittal of Preliminary Design Review is required

STEP 3: FINAL DESIGN REVIEW

This step is intended to review the specific designs for the architecture and landscape elements of the project.

Upon receipt of an approved PDRM, more detailed project plans shall be prepared and submitted to the BWARC for design review. Plans shall be a progression of the approved plan and direction established during Preliminary Design Review.

Professionals licensed to practice in the State of California shall prepare all Architecture, Civil Engineering, and Landscape Architecture plans. No non-licensed design work shall be permitted. Licensed building designers may be used only with the special approval of the BWARC.

SUBMITTAL REQUIREMENTS:

CIVIL / PLANNING

1. Dimensioned site plan showing:
 - Building footprints
 - Porches and patios
 - Garages
 - Street curbs and rights-of-way
 - Easements
 - Driveways and walkways
 - Dimensioned building setbacks
 - Compliance with project development standards
2. On all motorcourt or alley-served lots, utility coordination drawings, showing location and visual mitigation measured for all major utilities must be provided. Careful attention should be given to the placement of utility and irrigation cabinets, backflow preventers, and garbage bin locations to mitigate their visibility.

CHAPTER 1: DESIGN REVIEW

STEP 3: FINAL DESIGN REVIEW — CONTINUED

LANDSCAPE

3. Landscape Plans (minimum scale 1"=20') including:
 - Cover sheet with sheet index
 - Plant material and hardscape list and key, including finishes and colors of hardscape and fencing.
 - Typical landscape, planting, and irrigation plans for each unique footprint type and each lot type (i.e., corner lot, loop lot, or other non-standard lot).
 - Fencing, hardscape, and planting details.
 - Fencing site plan.

ARCHITECTURE

4. Architectural construction drawings, including floor plans, roof plans, secondary unit plans, alternative or options, all exterior elevations (including interior courts), sections, and key details, prepared at a minimum scale of 1/4"=1'-0").
5. Architectural color and material sample boards (or equivalent information as approved by the BWARC) for every color scheme by architectural style intended. These should be noted by elevation style for each product.

MISCELLANEOUS

6. Comment response memo identifying the steps taken to address BWARC comments from Step 2: Preliminary Design Review.
7. Estimated Construction Schedule for completion of the project, including improvements, model home complex site improvements, and phasing.

STEP 4: CITY SUBMITTAL

Upon receipt by the City of Davis Community Development Director of a complete application (including a BWARC approval letter) for Design Review, consistent with Section 40.31 of the Davis Municipal Code, the City will evaluate and determine the proposed project's consistency with Bretton Woods Neighborhood Design Guidelines, Bretton Woods Rezoning/Preliminary Planned Development Zoning Ordinance, and the City's other applicable requirements.

CHAPTER 2: NEIGHBORHOOD FRAMEWORK

Welcome to Bretton Woods in Davis, where the entire neighborhood is dedicated to providing residents with new energy efficient homes that meet their current and changing needs. Right-sized homes, an active lifestyle and a familiar location in the City you love offer the opportunity to downsize without sacrificing.

Just outside your door, find walking paths, an activity and wellness center including a health club open to the public, public art areas and attractive meeting and sitting areas. Explore nature. Mingle with friends. Take classes. Bretton Woods has thoughtfully designed an environment where exploration, gathering and tranquility come into perfect balance.

2.1. LOCATION AND SETTING

WEST DAVIS LOCATION

- Located West of Highway 113 with freeway access two blocks east
- Existing four-way intersection: Northwest corner of Shasta and Risling at Covell Boulevard
- Next door to Sutter Davis Hospital, Sutter Medical Offices and CommuniCare
- Across from University Retirement Community (URC)
- 1/4 mile to the medical offices of Dignity Health Care and UCD along Covell Boulevard
- The Marketplace shopping center is three blocks to the east across Highway 113

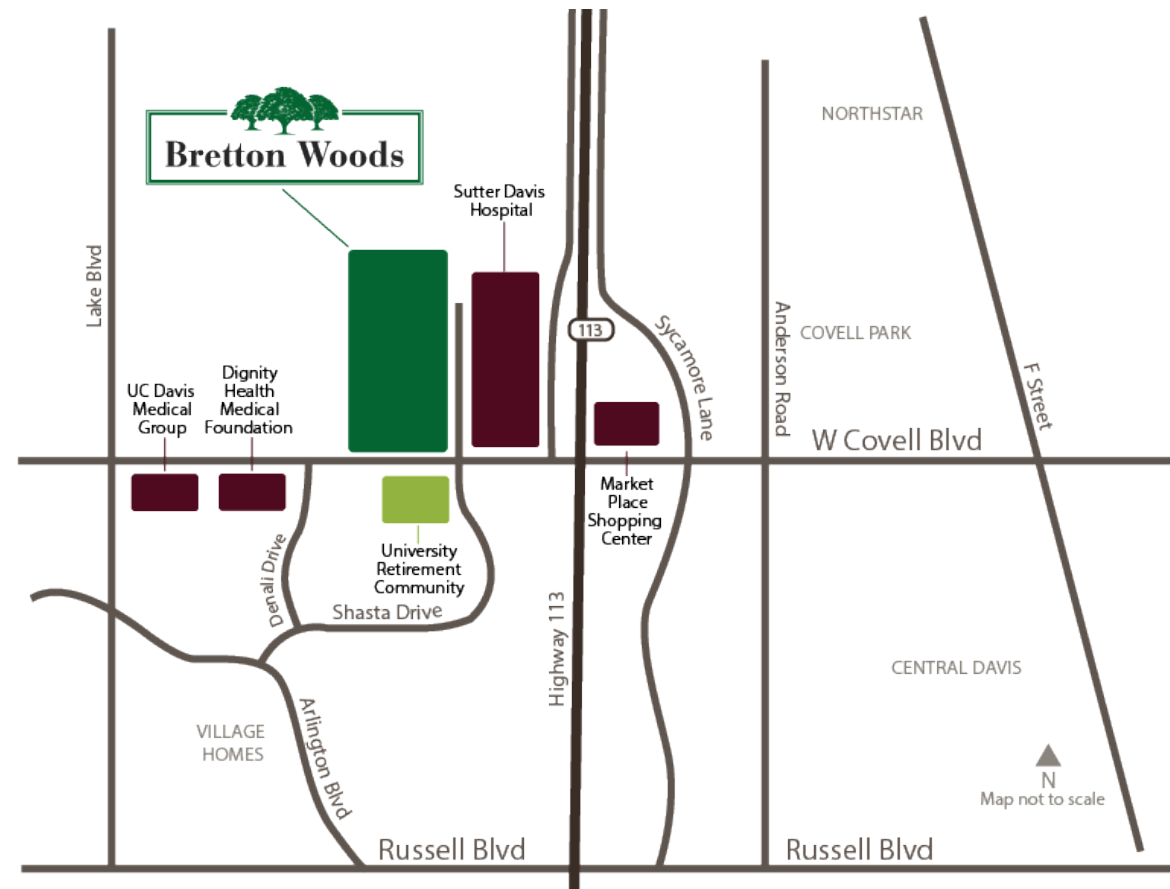

CHAPTER 2: NEIGHBORHOOD FRAMEWORK

2.2. GUIDING PRINCIPLES

The vision for Bretton Woods has been thoughtfully crafted to meet six specific criteria in an effort to develop the best community for future residents. The planning and development team was comprised of industry experts, consultants, neighborhood groups, city staff and other key stakeholders, all working in close collaboration to create this vision. Project approval included a commitment to achieving specific outcomes by fulfilling a clearly defined list of requirements and promises.

ONE: Promote health and wellness through an extensive open space and pedestrian system, outdoor recreation, social interaction and access to fresh produce.

From the beginning, the mission for Bretton Woods has been, “To elevate ‘age in place’ to ‘thrive in place’ with a thoughtful neighborhood design blending the inclusiveness of Davis with principles that enhance the older adult lifestyle.” To that end, the Bretton Woods neighborhood will include a Homeowners’ Association Club House and several additional commercial uses:

- Club house building with swimming pool and outdoor recreation and entertaining areas adjacent to the Sycamore Grove and tot lot, including a large class/multipurpose room for use by the Osher Lifelong Learning Institute (OLLI) and for other public and private events
- Separate building adjacent to the club house designed for medical telemedicine offices, a privately-owned fitness club open to Davis residents with access to the HOA pool for swimming related therapy and exercise services provided by the fitness club
- Coffee house open to the public is located adjacent to the club house and transportation hub
- 2 to 3 story office building located along Risling Drive at the entrance to the Activity and Wellness Center complex.
- Public restaurant site along Risling Drive with outdoor dining area located near the entrance to the Activity and Wellness Center complex.

In the 150-foot Bretton Woods Channel and agricultural buffer, a minimum of 350 oak trees will be planted, at least one for each home buyer in Bretton Woods. The 50-foot buffer area that borders the channel will include a multi-use path and planting beds available to the residents.

TWO: Expand traditional housing types to include a variety of lifestyle options through Universal Design, caretaker suites and a variety of densities to address a broad spectrum of residents.

“Our plan combines attractive Davis neighborhood elements with amenities for older Davis residents, their families and younger families. We are rearranging, reinterpreting and innovating a variety of features with sustainability and energy efficiency.” – WDAAC Planning Group

Bretton Woods will provide housing to meet various internal city needs featuring right-sized housing units, such as Greenway Homes, Cottages, Bungalows and Custom home lots where people can build homes that fit their unique needs. To support residents and their potential future care needs, caregiver suites may be built over the garage area in some of the Greenway homes and accessory dwelling units may be added in backyards of the Bungalows.

At 80% active adults and 20% unrestricted housing, Bretton Woods offers a balanced community catered to the diversity Davis provides. The project will also include parcels on Covell Boulevard for a specialized senior care facility

and subsidized apartment units for seniors aged 62 and above. The Bretton Woods community has an affordable housing plan that will exceed city requirements by double the required amount. The affordable apartment units will be located near transit and the health services of Sutter Davis Hospital and CommuniCare Health Centers.

THREE: Create an enhanced pedestrian and bicycle experience with a variety of destinations and focal points throughout the community’s street and trail network.

The neighborhood contains 2.6 miles of walking/biking paths within the property as well as an oak tree forest around the perimeter of the project. These paths will have 11 art exhibits plus related poetry exhibits scattered throughout the project.

Connectivity to the City’s other bicycle and walking paths is enhanced to provide Davis residents the ability to exercise within the neighborhood and travel safely to and from other areas in Davis.

FOUR: Create a sustainable neighborhood where environmental stewardship permeates all places, life and activities.

Bretton Woods has several environmental-related policies and activities that promote an eco-friendly lifestyle for all residents. Homes will be built to meet or exceed 2020 Net-Zero Electric Energy goals. In support of the City’s desire to reduce their carbon footprint and save energy, an Energy Retrofit Program for residents moving out of their previous Davis home has been developed (Energy Retrofit Package).

Additionally, the developer will plant an oak tree for each residence to transform the agricultural / landscape buffer along the North and West edges of the community into an oak forest. These trees can be adopted by people or families, and additional trees may be sponsored, to create a local legacy.

FIVE: Establish authenticity reinforced by the elements of community (The Third Place, Connectivity, Walkability, Placemaking, Wayfinding, Meaningful Open Space, Cultural Infrastructure) to create a strong sense of place.

Bretton Woods features the largest public art display ever proposed in Davis. Containing 11 individual spaces dedicated to displaying, admiring and appreciating art, including some designed by the artists of our city, these pieces are thoughtfully placed around open space and walking areas within Bretton Woods.

The many walking paths, small parks, seating areas and indoor spaces in the community provide spaces away from home and work for neighbors and Davis residents to congregate, interact and build community over shared experiences and to learn and create new memories and friendships.

SIX: Establish a distinctive and authentic architectural and landscape character of re-interpreted American styles.

Master builders will offer home designs in multiple distinct styles, including Contemporary Ranch, Craftsman, English Cottage, French Country Cottage, Mid-Century Ranch, Modern, Modern Contemporary, Modern Farmhouse, Spanish and Spanish Modern.

Custom home designs will be developed with architectural detailing to ensure design integrity is maintained throughout the community.

CHAPTER 2: NEIGHBORHOOD FRAMEWORK

2.3. LIVABLE DESIGN PRINCIPLES

The entire Bretton Woods community has been designed to encourage an active lifestyle for residents of every age. Extensive walking trails, community vegetable gardens, an activity and wellness center and the community club house offer the opportunity to fully engage with the community on a variety of levels based on each individual's lifestyle preferences and mobility. Bretton Woods is intentionally designed to address the growing preference for residents who wish to "age in place" – that is, to enjoy accessibility and safety throughout their homes and communities that is supplemented with future consideration for additional support and services as they age.

This includes Universal Design principles in all common areas and buildings, multiple dwelling types ranging from detached, stand-alone private residences to service-enriched multifamily buildings to the future potential for a University Retirement Community on site. This array of options in combination with thoughtful space and amenity planning will allow Bretton Woods residents to enjoy their community regardless of their life stage. As they age, residents will be able to find homes, amenities, activities and services they need to continue living full, enriched lives – without ever having to move out of the neighborhood.

Home design within Bretton Woods will integrate principles of Universal Design and visitability subject to The City of Davis Universal Design Checklist. This approach responds positively to the City's objective of supporting aging-in-place and the City's visitability requirements for new home design, which address the qualitative and quantitative aspects of incorporating supportive features and integrated design elements into new home designs.

Bretton Woods Universal Design includes the following considerations:

- Homes will be designed to be built with a zero threshold at the front door, with an option to achieve the same at the garage door into the home.
- Homes will be designed to have a 36" wide minimum path of travel at the interior of the home, with access to all rooms and spaces within the home.
- Homes will be designed to have at least one accessible bathroom on the primary floor (ground floor), with backing for grab bars.
- Homes will have an accessible common room outside of the Kitchen (Great Room).
- Homes will be designed with at least one accessible Bedroom.
- Homes will be designed to have an accessible path of travel in the Kitchen.

In addition to the items listed above, the following items help us achieve conformity with the Universal Access Ordinance.

- Doors used for circulation throughout the home are designed at a minimum of 2'-10".
- Homes are designed to allow at least one bathroom to have a 42" x 48" roll-in shower with a 36" wide door.
- The use of rocker light switches and single lever door fixtures are specified across all plans.

EXAMPLE UNIVERSAL DESIGN ELEMENTS

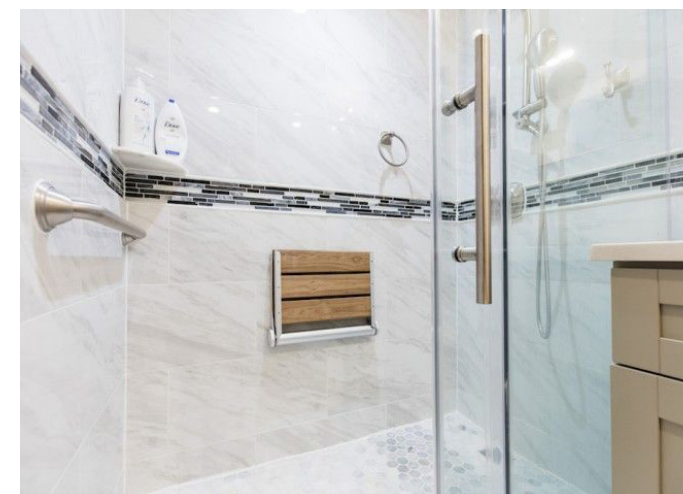
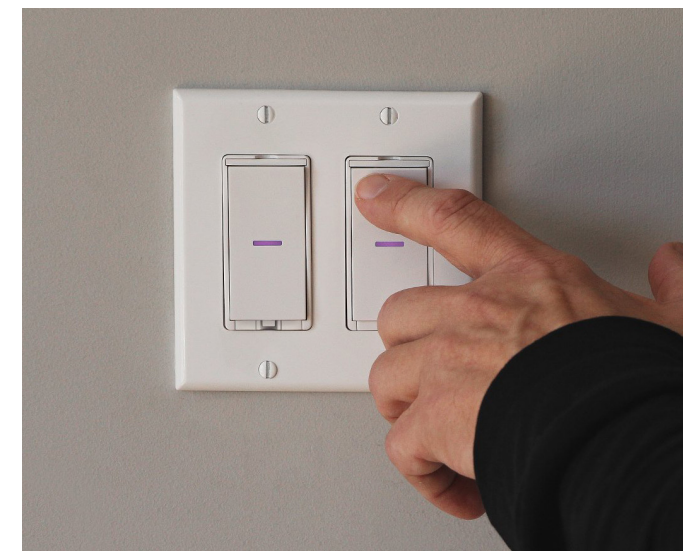

CHAPTER 2: NEIGHBORHOOD FRAMEWORK

2.4. SITE PLAN

The Bretton Woods active adult community in West Davis is located at the northwest corner of Covell Boulevard, west of the Sutter Davis Hospital and across the street from the University Retirement Center. The 74 acre site will include single-story homes with a variety of floor plans and square footages. The community offers 2.6 miles of shady walking and biking paths with opportunities to interact with the environment and enjoy public art.

Highlights of the site:

- Centralized park with playground
- Greenway walks, mailbox kiosks and other common spaces that encourage resident interaction
- Art walk path featuring local artwork open to schools for field trips
- Community Club House*
- Activity and Wellness Center*
- Business Offices*
- Restaurant*
- Agricultural buffer / Arboretum with native, pollinator-friendly plants
- Additional designated single/multifamily (future development)

* Not included in these submittal guidelines; will be submitted at a later date.



CHAPTER 2: NEIGHBORHOOD FRAMEWORK

2.5. COMMUNITY CONNECTIVITY

2.5.1. WEST COVELL BOULEVARD

The existing Covell Boulevard streetscape will be revitalized with trees and ground plane plantings to create an enhanced front door into the community. A custom designed entry monument will be placed at the intersection of Covell Boulevard and Risling Court, the main vehicular access into the development. Large oak trees will enhance the monument. A pedestrian bridge over the drainage canal links the Covell multi-use sidewalk to the Arboretum, Art & Poetry Trail and community paths meandering through the project site.

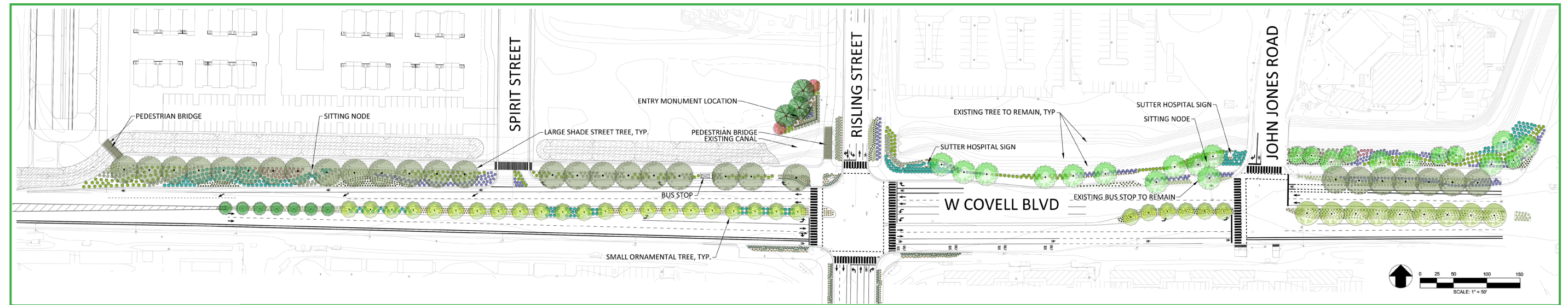

Fig. 1

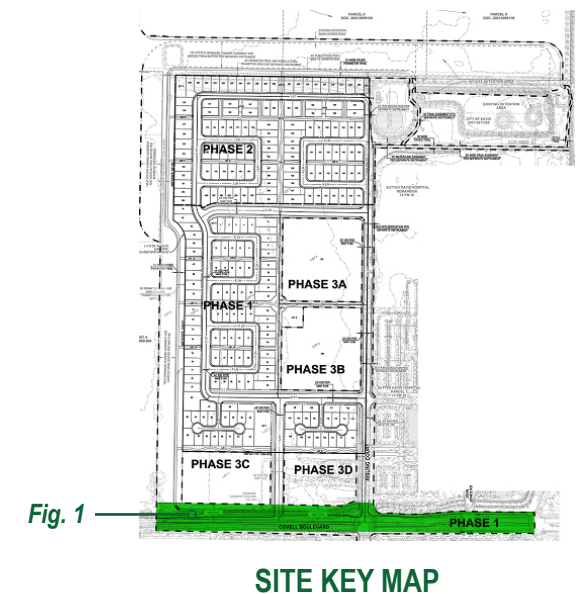
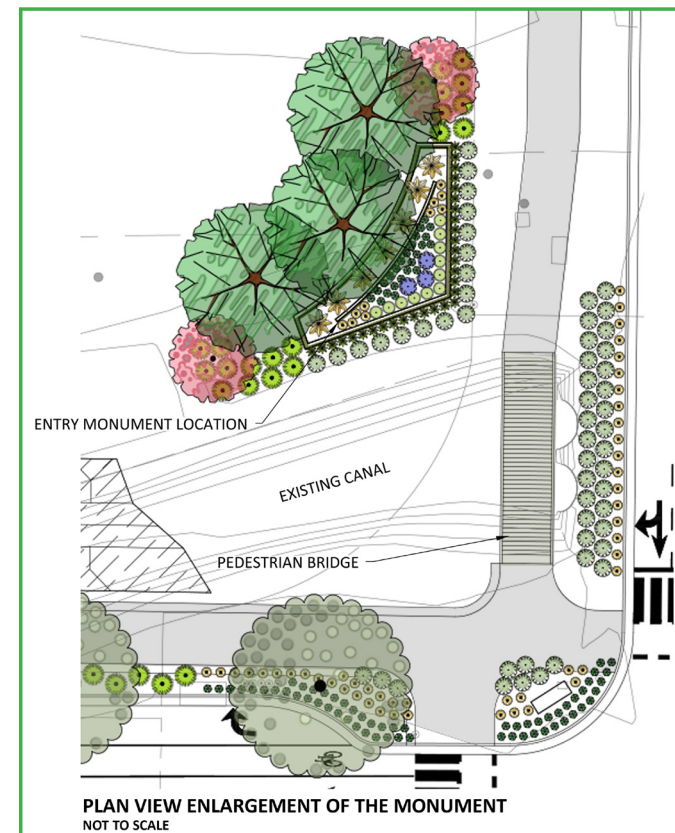

Fig. 1

CHAPTER 2: NEIGHBORHOOD FRAMEWORK

2.5.2. NORTH/SOUTH PEDESTRIAN PATH

Homes situated along the North/South pedestrian path front on a scenic, meandering pathway, lined with large canopy trees and decorative lighting which connects to the other neighborhood pedestrian corridors. Residents on their way to the clustered mailboxes can say hello to neighbors relaxing on their porches and enjoy amenities such as park bench seating and conveniently placed waste receptacles.



Fig. 1



ROSE SHRUB AT HOME ENTRY

2.5.3. ARBORETUM, ART AND POETRY TRAIL

The art walk is comprised of 11 individual commissioned art pieces. As a destination and strolling garden, the walk is open to residents as well as the local schools and UC Davis art programs. Residents, students and visitors can meander along the well-marked path to the art destinations. Here they can gather, view, learn, sit, ponder and enjoy the artistic elements and educational signage within the community.

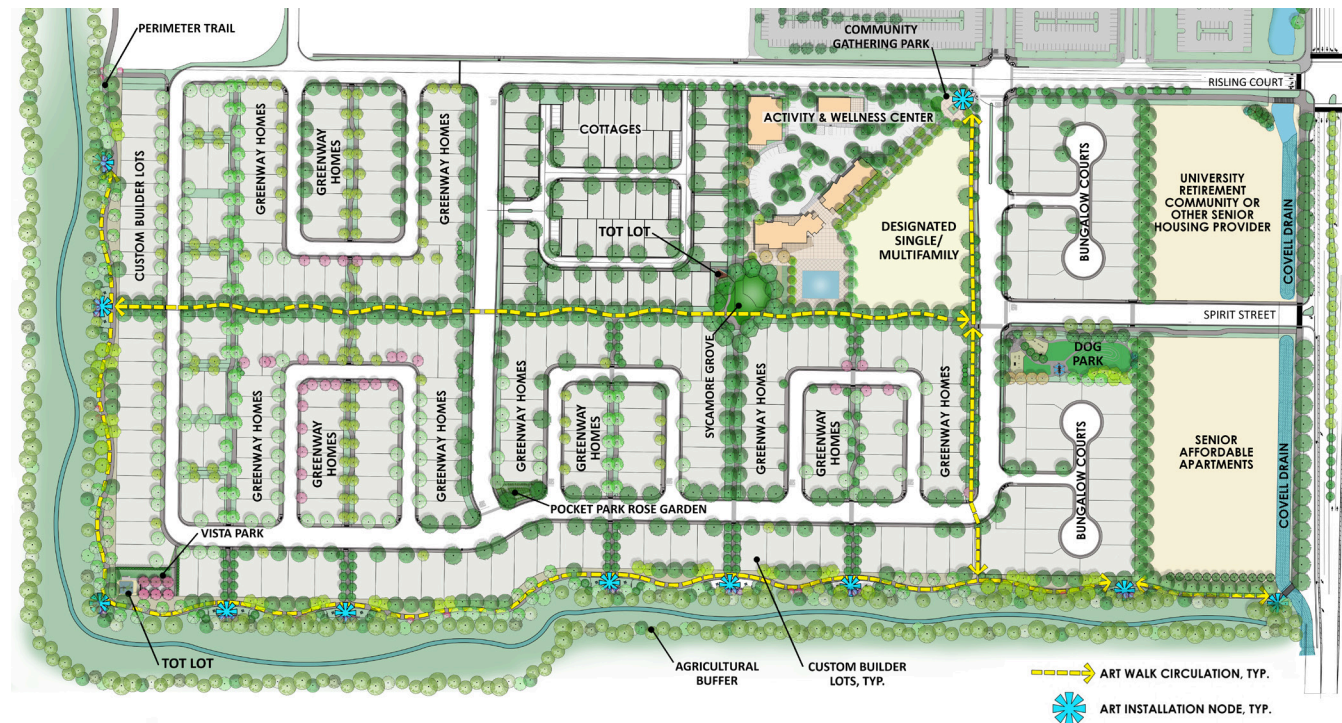

2.5.4. OAK FOREST

The West and North perimeter of the community consists of an agricultural buffer which will include an oak forest area comprised of one tree for each home at Bretton Woods.



Fig. 2



2.5.5. ART NODES

The art nodes along the perimeter pedestrian path will offer a place for commissioned art to be installed within a raised planter with ornamental plantings. Stabilized decomposed granite or asphalt paving will surround this planter and have bench and table seating opportunities for viewing the art and agricultural buffer which will have large trees that will provide cool shade to the art nodes. Interpretive signage will also be included around the art nodes to provide educational information about the art. The community will include directional signage and maps to the art nodes.

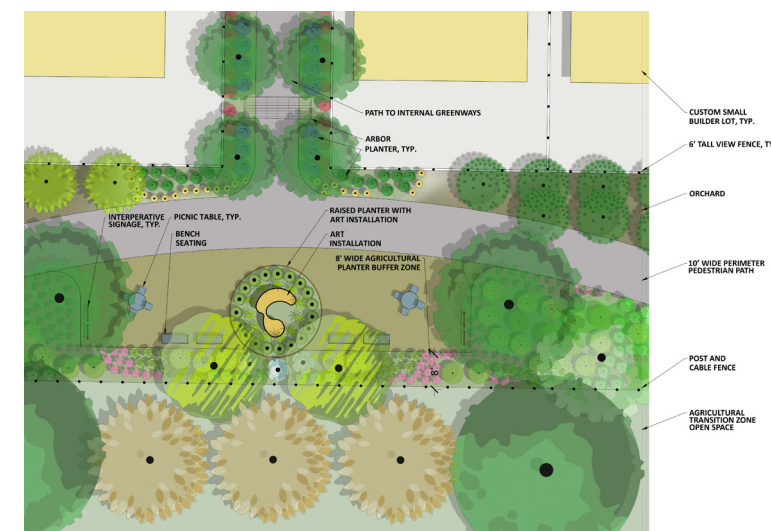
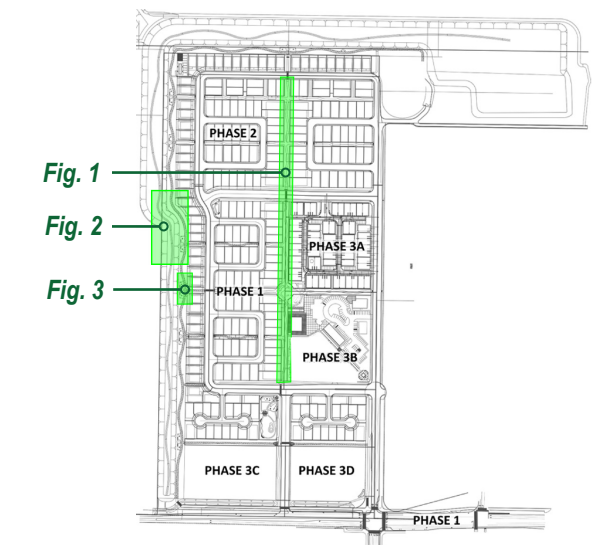

Fig. 3



SITE KEY MAP

CHAPTER 2: NEIGHBORHOOD FRAMEWORK

2.6. PARKS AND COMMUNITY SPACE

When creating the vision for Bretton Woods, the planning and development team identified their number one guiding principle to be promoting health and wellness. An extensive open space will provide opportunities for outdoor recreation and social interaction. Over 19.5 acres are dedicated to parks and open space with a variety of amenities to meet all residents at their current and changing activity levels. Detailed programming and design for construction documents will be developed in partnership with the City of Davis Recreation and Parks Department.

2.6.1. SYCAMORE GROVE

Located in the heart of the project adjacent to the proposed Activity and Wellness Center, Sycamore Grove offers multiple landscaped spaces for concurrent recreation and relaxation opportunities. A large lawn area can accommodate outdoor music concerts and community events, as well as semi-private weddings, retirement parties and graduation celebrations. A tot lot playground area, edged with shade trees and bench seating, will engage the littlest grandchildren.

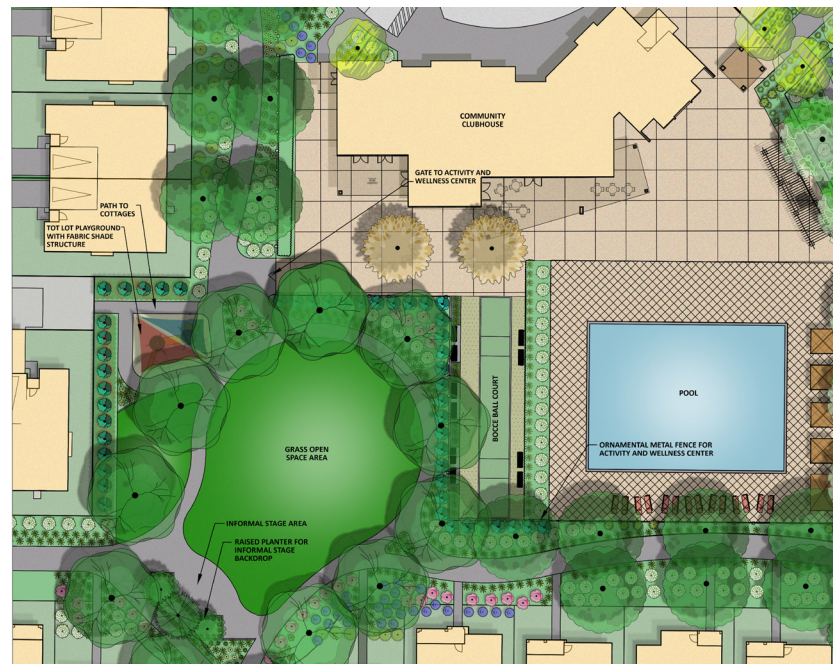

Fig.1



EXAMPLE OF A TOT LOT PLAYGROUND



EXAMPLE OF A COMMUNITY EVENT WITHIN A PARK OPEN SPACE

2.6.2. ROSE GARDEN POCKET PARK

At just under 3,000 square feet, this pocket park plays off of the rose bushes at each home entry by offering a rose garden for people to enjoy as they sit at one of the two seating nodes or by walking through the site on stabilized decomposed granite or asphalt paths. The rose garden will feature a variety of rose types and colors and will have identification signage for each type of rose. In addition to the roses, ornamental trees will be placed within the planters to provide shade and a central focal point within the garden.



Fig. 2

2.6.3. VISTA PARK

Vista Park is in the northwest corner of the site surrounded by the perimeter walk and oak forest. It provides residents with another gathering space along with some active and passive recreation. Amenities include a bocce ball court, a small playground with a fabric shade structure, a passive turf area, and benches for the bocce ball court and playground. The park will have a ramp and stairs connecting it to the perimeter pathway. Vista park is elevated above the adjacent perimeter walk and oak forest, giving residents a better view of the surrounding environment, one of the twelve art nodes (refer to Art Nodes in this section), as well as stunning sunsets to the west. Built-in benches will overlook the bocce ball court and playground which are both adjacent to the turf area running north south through the park site. At the southwest corner of Vista Park there will be stairs and a ramp to connect this site to the adjacent perimeter pathway. Landscape planting will be limited due to most of the site taken up by the bocce ball court, playground and turf area. On either side of the bocce ball court there will be two 6' wide planters with low growing shrubs and accent shade trees. Planting adjacent to the houses on the east and south side of the park will consist of a narrow but tall vegetated buffer to provide privacy. Concrete walks will connect park users to all the amenities.



Fig. 3



Bocce ball court with spectator / player seating



Stabilized decomposed granite paving



Vegetated buffer at adjacent residential lots



Tot lot playground with fabric shade shelter

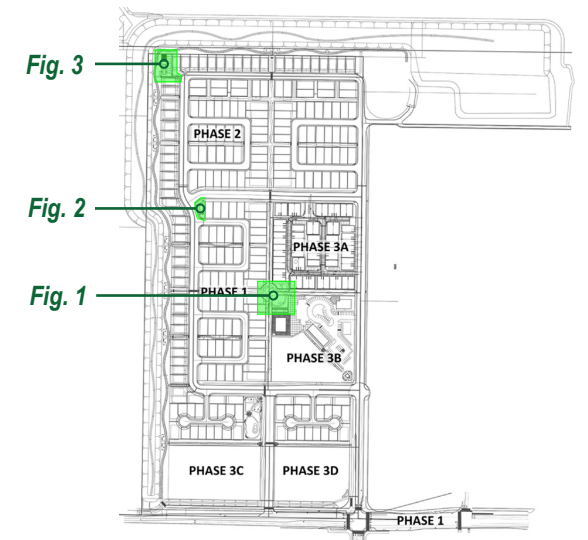

Fig. 3

Fig. 2

Fig. 1

SITE KEY MAP

CHAPTER 2: NEIGHBORHOOD FRAMEWORK

2.6.4. DOG PARK

Located centrally within the project site, this .58-acre area has been designated to accommodate the recreational needs of the community's canine companions. A giant embedded paw print welcomes residents at the southwest entry. A central shade pavilion with integrated and unique "twig" seating provides a relaxing spot for pet owners. Separate agility courses for large and small dogs incorporate naturally bermed turf grass for interest. Accessible paved paths connect all areas of the park, which is fully fenced with puppy panels for safety. The park offers a central kiosk, drinking fountain, and multiple doggy waste stations.



Fig. 4

2.6.5. COMMUNITY GATHERING PARK

The park is located on the northwest corner of the intersection of Thomson Loop and Risling Street adjacent to the activity and wellness center. The park will be a gathering place for all residents and will have a raised planter centered within a concrete plaza surrounded by trees. The raised planter will have one of the 11 art nodes placed along pedestrian connections throughout the site. The park will include benches to provide pedestrians a place to rest and socialize with other residents.



2.6.6. ACTIVITY & WELLNESS CENTER (GROUNDS)

In addition to the numerous outdoor activities available to Bretton Woods residents, the community also offers an on-site Activity and Wellness Center. This facility is staffed with trained health and fitness professionals and equipped with the latest strength, flexibility and cardio equipment. Group classrooms for instructor-led courses in aerobics, yoga, circuit training and other exercise activities are also available. The Activity and Wellness Center is easily accessible by foot from multiple access points.

The Activity and Wellness Center is surrounded by large street trees within the parking lot, medium size trees throughout the site and smaller accent trees at entries and focal point areas. Shrub and ground cover planting will include many of the same native, pollinator-friendly plants found throughout the site and will bring accents of color and interest to the landscaping.



Fig. 5

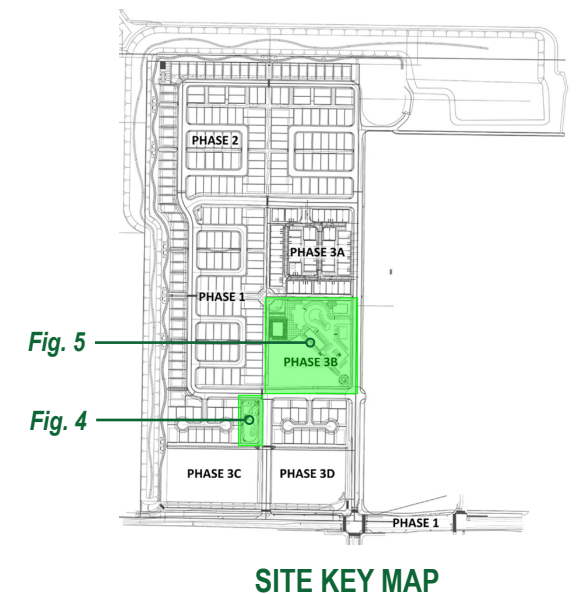

SITE KEY MAP

CHAPTER 3: LANDSCAPE DESIGN

3.1. INTRODUCTION

At Bretton Woods, the traditional concept of a “senior neighborhood” will be revolutionized. Landscape design at each homesite and throughout the entire community is a major component of that revolution. Ultimately, connecting residents with nature and the environment is a key component in developing a strong community and active lifestyle.

This document defines guidelines and standards for all landscape areas within the Bretton Woods community. This includes homesite landscaping, parks and open space, planting design principles, and site furnishings and materials. All the recommendations made within this document are intended to create an accessible, coordinated, cohesive landscape for the residents of Bretton Woods. The residents will have a wide range of mobility, from those who are extremely active to others with limited movement. Therefore, the landscape will include multiple active and passive elements. These features will enhance the ability to “age in place” while connecting to the environment.

Each area of Bretton Woods has been carefully planned to ensure appropriate plant selections and variety of heights, textures and colors will help create a vibrant, engaging outdoor environment. Builders and home owners should reference the parameters and expectations laid forth in these Design Guidelines to ensure individual homesite landscape plans comply with the overall community intent for landscape design at Bretton Woods. Each homesite has the potential to help set the Gold Standard of strength, beauty and environmental awareness through the design, installation and maintenance of high quality landscaping.

Over the centuries, no other flower has evoked the same devotion as the rose. This magnificent flower is the Gold Standard of flowers symbolizing strength and beauty. Bretton Woods received its name because it too is a housing Gold Standard. Named in honor of the location of the famous economic conference held in 1944 to establish post-World War II monetary policies, Bretton Woods in Davis sets the Gold Standard for an aging in place neighborhood. Planted in front of each home will be a rose with its color selected by the owners to represent the ethos that will sustain Baby Boomers and future generations to come.

The governing HOA for Bretton Woods will oversee installation and maintenance of all community-wide landscape features, plantings, parks, amenities and other elements. The Master Builder is responsible for design and installation of individual homesite landscaping, with plans subject to review and approval by the HOA. Custom home builders and owners are responsible for design and installation of individual custom homesite landscaping, with plans subject to review and approval by the HOA.

CHAPTER 3: LANDSCAPE DESIGN

3.2. RESIDENTIAL CONNECTIVITY

3.2.1. GREENWAY HOMES

Greenways are groupings of homes where the front doors face a greenway and the garages have access to the perimeter street. Each greenway includes a meandering pedestrian pathway, an arbor trellis structure marking the entrance from the neighborhood street, seating nodes with benches and trash receptacles, and one mailbox kiosk. Vinyl privacy fencing will separate lots. The landscaping within each greenway will be consistent to help define place within the project site. A mix of large shade trees, small to medium accent trees and shrub planting will provide a welcoming feel to each porch. The concrete path leading to each brightly painted front door will be marked with a rose bush to further tie the landscape together throughout the project site. The pathway shall meander through the lot, and it will be lit on the greenway side by 8' tall pole lights spaced to provide adequate lighting for safety. Streetscape planting along the perimeter streets will include small to medium street trees and shrubs in planters. All greenways lead to the North/South Pedestrian Path and the Perimeter Pedestrian Path/Art Walk, providing access to the entire site while allowing residents to meet their neighbors in a safe environment.



6' TALL PRIVACY WOOD FENCE EXAMPLE



ROUNDED METAL ARBOR EXAMPLE



BENCH



TRASH AND RECYCLING RECEPTACLES



MAIL BOX CLUSTERS



ROSE BUSH AT HOME ENTRY



RESIDENTIAL LIGHTS AND POST EXAMPLE



CHAPTER 3: LANDSCAPE DESIGN

3.2.2. SINGLE-LOADED GREENWAY HOMES

Single-loaded Greenway Homes have front doors and garages facing a neighborhood and/or perimeter street, with on-street parking. A rose-covered arbor will be placed at approximately every third street parking space. Spaced between the arbor structures will be small accent trees. The landscape area behind the pedestrian walkway will have large street trees and distinct shrub plantings. Each Single-loaded Greenway Home will have a rose bush planted to provide an identity to this area within the site while tying into the overall community. The Single-loaded Greenway Homes all lead to the North/South Pedestrian Path and Perimeter Pedestrian Path/Art Walk, providing access to the entire site while allowing residents to meet their neighbors in a safe environment.



METAL ARBOR EXAMPLE



6' TALL PRIVACY WOOD FENCE EXAMPLE



ROSE BUSH AT EACH HOME ENTRY

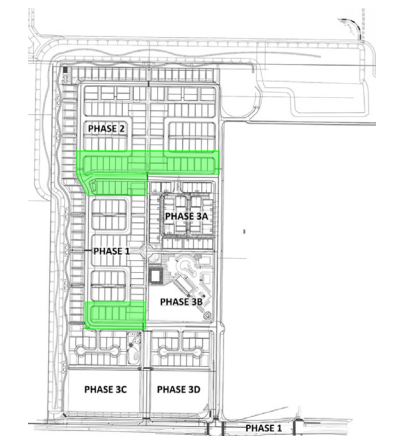

CHAPTER 3: LANDSCAPE DESIGN

3.3. PLANTING DESIGN PRINCIPLES

The goal of the Bretton Woods landscape design guidelines is to ensure cohesive, regionally appropriate, community-wide landscape and hardscape elements. This includes careful attention to tree species and placement, individual lot specifications for plantings, a thorough plant palette of acceptable selections, specific installation guidelines to ensure health and longevity of plants, and community themed lighting and signage. These elements apply generally to the entire community, with specific variations based on homesite location and product type. Landscaping of public spaces and amenity buildings as well as any future development and construction are subject to oversight by the HOA.

3.3.1. OVERALL PLANTING GUIDELINES

The guidelines listed below apply to all initial planting within Bretton Woods. Landscaping within the community will be adjusted based on special requirements identified through soils or drainage studies. All plant material is to be selected from the plant palettes in Appendix B, with priority to native plants. Certain areas within the project site require specific plants, and in these locations, substitutions will not be allowed. If needed, substitutions or additions can be considered based on similarity of form, adaptability to on-site soils, climate conditions and water quality, or any pertinent characteristics. The included plant palette is not exhaustive but intended to help give clear direction for plant selection. Additions to this list must be compatible and fall under the intent of these guidelines.

Landscape design should consider year-round interest and seasonal character through the placement of flower and leaf color. Planting design should provide a screen for parking areas, utility enclosures or cabinets and service areas or corridors to reduce negative visual impacts. Landscaping should use evergreen plant species to maintain year round screening. When choosing trees, avoid species with invasive root systems near utility lines and paving. When choosing plants, avoid the use of non-native, invasive species that may easily spread into adjacent open space areas.

All plant material should be selected to avoid species that could be harmful to children or cause allergic reactions. In all areas where the developer is required to install landscaping, the plans will be prepared by a licensed landscape architect registered to practice in the State of California.

3.3.2. ON-SITE RESIDENTIAL LANDSCAPE

All areas to be landscaped outside the 6' vinyl fencing for individual lots will be provided by the developer. With the exception of the Custom Homes and the Single-loaded Greenway Homes, all front yards are adjacent to common space greenways. All residential lots (including front yards of Custom Homes) will be maintained by the HOA. All landscaping shall be designed cohesively and be seamless so as not to individualize each lot or common green space. Front yard irrigation shall be provided as part of the overall irrigation system and not per each individual lot.

New homeowners can choose to have a fruit tree planted in their front yard at the time of their initial purchase. The tree shall be selected from the list of self-pollinating fruit trees on the approved plant palette in the design guidelines. The fruit tree will be planted by the builder, irrigated by the HOA and maintained/harvested by the homeowner. Fruit from the trees is intended for the individual homeowner use but can be shared with residents within the community as available.

3.3.3. AGRICULTURAL BUFFER

The agricultural buffer is located along the north and west sides of the neighborhood. The external portion of the buffer includes the drainage channel while the 50' interior portion of the buffer includes the perimeter trail area. A minimum of 350 oak trees will be planted within the agricultural buffer area. The 50' interior area will include art and habitat nodes with pollinator friendly plants.

Community vegetable gardens may be incorporated within the 50' interior portion of the agricultural buffer area.

3.3.4. IRRIGATION AND WATER CONSERVATION

The irrigation system for Bretton Woods will be designed to conserve water through the efficient use and uniform distribution of water. The design of the irrigation system should follow the City of Davis Water conservation ordinance. Irrigation will be provided via a well located on the southwest corner of the project site. Irrigation shall be installed as a reclaimed purple pipe system. All valves, piping, valve boxes, etc. shall be installed accordingly. Low volume spray heads and drip irrigation systems should be used throughout the project site.

All community landscaping should have an automatic central controlled irrigation system with a rain shutoff valve. Irrigation design should take into consideration hydrozones. Designs should separate high, medium and low water-use plants as well as the plants' sun exposure.

Shrubs and turf should be irrigated with a drip system or MPR heads to provide deeper, more even watering. Trees should be placed on separate valves and irrigated with deep water bubblers.

Moisture sensors should be installed at appropriate locations throughout the project site to minimize over-watering.

3.3.5. DROUGHT TOLERANT LANDSCAPE

When selecting plants, the design should prioritize the use of native, adapted native, drought-tolerant, long-lived and pest-resistant species. Priority should also be given to the UC Davis Arboretum All-Stars and plants that are indigenous to Davis and well-suited to the climate and soil conditions of the community.

Turf will be limited to parks or other active use areas. Low groundcover and native grasses should be used as an alternative to turf wherever possible.

Plants with high water demands should not be used on site. In areas where they are used, they are to be located in shade or where more runoff occurs.

CHAPTER 3: LANDSCAPE DESIGN

3.3.6. MASTER BUILDER SERIES LOT DESIGN

Details about neighborhood landscape design elements was discussed above in sections 3.2.1. and 3.2.2. Individual lot landscape design is subject to approval by the Bretton Woods HOA. Typical Master Builder Series lot design examples are illustrated below.



CHAPTER 3: LANDSCAPE DESIGN

3.3.7. CUSTOM HOME LOT DESIGN

Owners of custom homesites have the opportunity to design their own unique landscape plan that complements their personal style and home design. Bretton Woods recognizes the value of individuality among custom homesites as long as landscape plans maintain the overall continuity of look and feel for the entire community. This includes adherence to the approved plant palette, attention to setback requirements, intentional layering of groundcover, ornamentals, and larger trees, and the need to follow all necessary approval channels prior to installation.

Ultimately, custom homesites offer owners the opportunity to extend the cohesive, connected natural environment of Bretton Woods to their own front doors. Custom homesite owners and contracted custom home builders are responsible for installing landscaping that meets all requirements of these design guidelines, subject to approval by the BWARC.

A typical custom home lot design is illustrated below.

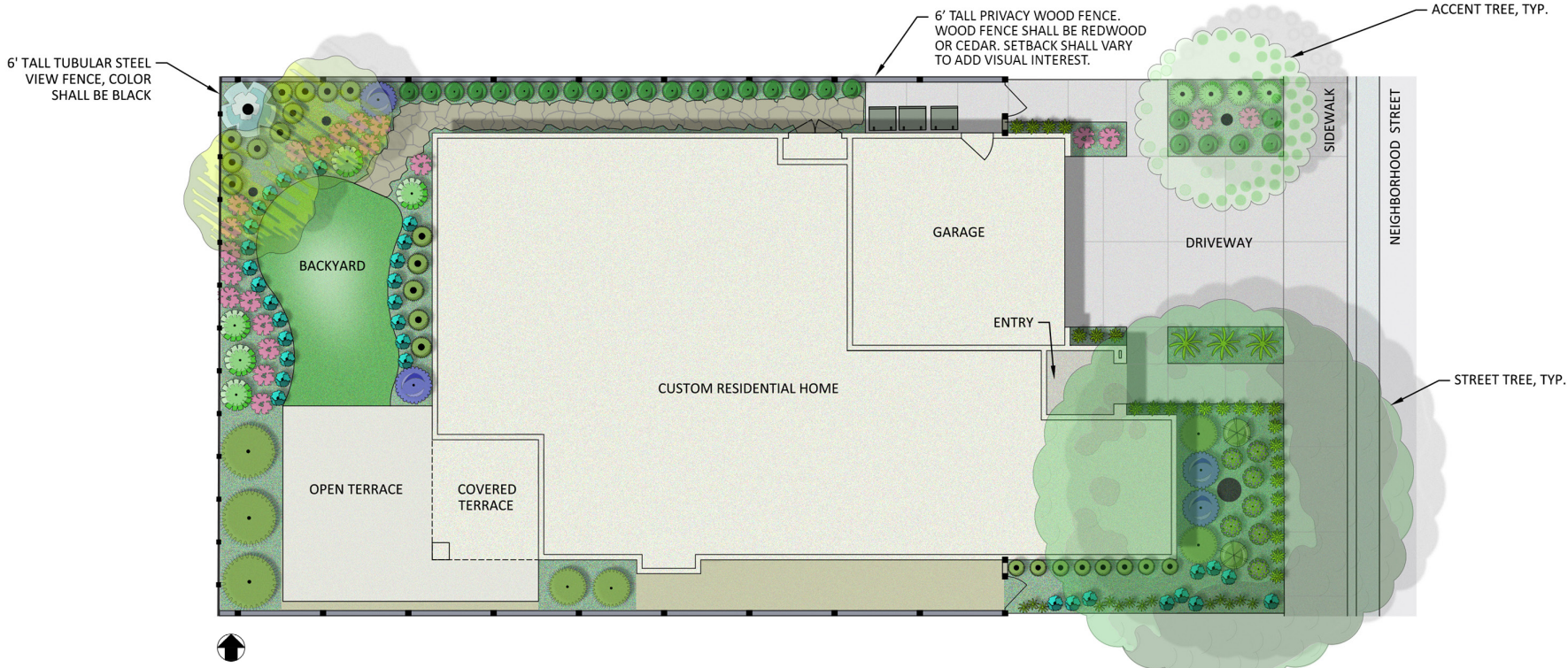

CUSTOM HOME LOT

CHAPTER 3: LANDSCAPE DESIGN

3.4. SITE FURNISHINGS AND MATERIALS

All site features, elements and materials shall be designed or selected to minimize ongoing maintenance and maximize life cycle costs, while deterring or resisting vandalism potential.

3.4.1. LIGHTING

Efficient lighting design will be used to improve community use of pedestrian pathways in the evenings and at night. The developer will use high efficiency fixtures to direct light where it is needed, avoiding excess glare and impacts on open space. Lighting will be used to help differentiate use areas, emphasize amenities, provide continuity within the project site and promote safety in the community. The variety of light fixtures for Bretton Woods will be a related group of decorative fixtures including spot lights, bollards, decorative pole lights, and street lights. Community lighting will be complemented by cohesively designed residential lot and dwelling light fixtures.

3.4.2. SIGNAGE

Bretton Woods will have signage in multiple locations from entries to parks and to the art walk. All signage will be the same font and material to maintain unity throughout the community. Representative examples provided at right.

3.4.3. SITE FURNITURE

Benches, tables, bollards, bicycle racks, trash receptacles and lighting standards are to be part of the initial site design as one family of elements, to create one visual element. Site furniture should be compatible in size, design and color with the surrounding buildings and landscape design but not overwhelm the landscape.

3.4.4. FENCES AND GATES

All greenway home residential fences on site shall be wood, and they will be erected in every side and backyard of the lots on Bretton Woods. Cottage homes that back to the greenway will have open view fencing along the greenway side of each lot. The custom homes shall have wood side yard fencing and open view fencing along the rear property line overlooking the oak forest. Fencing and gates shall be subject to approval by the BWARC.

- All fences shall be wood, except that tubular steel or other metal open view fencing is required on the rear lot lines of the custom homes and the cottage homes that back up to the greenway.
- Fences shall be 6'-0" in height and have a similar look on both sides.
- The wood fencing shall be 6'-0" tall. Fence material shall be redwood or cedar.
- Gates shall match fencing, to be equivalent colored wood or metal.

3.4.5. PAVING AND HARDSCAPE

All 10' wide (or larger) major pedestrian pathways within the Project Site are to be asphalt. Accent paving will be used throughout the project to define entrances to different spaces. Narrower walkways i.e. to front doors of residential units and sidewalks adjacent to the public roads will be traditional concrete material. All paving accents to delineate and announce entries will decoratively scored and designed to fit in with the overall site.

3.4.6. ANCILLARY STRUCTURES

- Small sheds, no higher than the fence, shall be allowed at side yards with HOA approval.



EXAMPLE WAYFINDING SIGNAGE



CHAPTER 4: DESIGN GUIDELINES – MASTER BUILDER SERIES

4.1. MASTER BUILDER SERIES DESIGN PRINCIPLES

Residential neighborhoods within Bretton Woods are comprised of a variety of distinct housing types interconnected by a logical system of tree-lined walkable streets, neighborhood-serving mixed-use, open space, and community spaces. By employing an authentic architectural palette and creative site planning techniques, Bretton Woods will embody a strong architectural identity to create an iconic and sustainable neighborhood within the City of Davis. These guidelines and standards articulate the lot characteristics, setbacks, garage type and orientation, and building massing for each housing type. In addition, this chapter establishes general expectations for architectural design and execution for all product types at Bretton Woods. Final approval of all proposed designs is subject to review by the Bretton Woods Architectural Review Committee.

4.1.1. STREETSCAPE DIVERSITY

An eclectic and diverse streetscape is a defining characteristic of enduring landmark neighborhoods. Simple and elegant planning and design elements can change the essence of a community while maintaining an overall unified theme. The intent of this section is to articulate the standards and unique defining elements by which the residential neighborhoods of Bretton Woods shall be built in order to create an animated streetscape with a diverse character.

MASTER BUILDER SERIES

To achieve streetscape variation, the Master Builder Series includes a minimum number of master home plans with associated elevations, each of a different architectural style, per each individual sub-neighborhood, district, or lot size/type within Bretton Woods based upon the number of lots to be built upon by one builder as an individual project within the neighborhood. Further, a certain number of architectural styles is required, which will be applied based on appropriate massing (i.e., every floor plan will not have every architectural style applied. For example, the California Eclectic style is only appropriate for a two-story home.). Certain sub-neighborhoods will benefit from a greater number of elevations per floor plan and architectural styles, whereas others may benefit from a more cohesive palette. This selective architectural style application will enhance the eclectic nature and variety of the streetscape. Master Builder Series home plans are defined as unique floor plans with a distinct footprint with regard to placement and relationship of garage, front door and building massing.

REPETITION

Avoiding repetition of identical floor plans or architectural styles is important to create a sense that a neighborhood has been built over time.

- In the areas of the neighborhood with a traditional home-to-street relationship (Greenway Homes, Bungalows, and Cottages), the same floor plan with the same elevation shall be no less than three (3) lots away in any direction (on the same side of the street as well as the opposite side of the street). (This requirement is not applicable to single family attached or multifamily).
- It is appropriate to exhibit a cohesive architectural theme within certain home types to create a village concept (Greenway Homes, Bungalows, Cottages and Custom Homes). Deviation to the repetition requirement is allowable within these sub-neighborhoods.

4.1.2. HOME TYPES AND SIZES

Type	Bedroom Count	Square Footage
Cottages: Single Story	2-3 Bedrooms	1,200 +/- s.f. maximum
Bungalows: Single Story	2-3 Bedrooms	1,350 +/- s.f. maximum**
Greenway Homes: Single Story*	2-3 Bedrooms	1,875 +/- s.f. maximum

For additional details, refer to Section 6.1. “Final Planned Development Table”.

* A caregiver suite, visitor space or personal office is permitted as additional square footage within Greenway Homes but shall be limited to the general area over the garage as a limited exception to the single story requirement. One caregiver suite will be allowed per lot. The caregiver suite will be allowed to have a bathroom (toilet, sink, bathtub and/or shower) facility and one kitchen with cooking facilities. The caregiver suite shall not be flush with garage door wall and shall be set back to provide architectural articulation.

**A stand-alone caregiver/accessory dwelling unit is permitted as additional square footage. One caregiver suite will be allowed per lot. The caregiver suite will be allowed to have a bathroom (toilet, sink, bathtub and/or shower) facility and one kitchen with cooking facilities.

CHAPTER 4: DESIGN GUIDELINES – MASTER BUILDER SERIES

4.1.3. EXTERIOR LIGHTING AT DWELLING

REQUIRED CHARACTERISTICS

- Exterior residential lighting shall convey a warm, inviting atmosphere and aid in providing night time security without annoying others. Selection and placement of fixtures, and selection of light source types, should be done with care. Exterior illumination of architectural features such as columns, entries, chimneys and landscape features is encouraged.
- Address signs will be internally illuminated. Ground lighting or decorative light fixtures are encouraged. Decorative fixtures shall be of high quality materials and workmanship and be in scale and style with the home.
- Exterior lighting shall be installed in a manner that is not unsightly or the cause of unnecessary light pollution, distraction or nuisance.
- All lighting shall be reviewed and approved by the BWARC. Example images shown here provide guidance for design intent only.

ENCOURAGED

These homes all have exterior lighting which is scaled for the application. Down-lighting and all applied fixtures are placed correctly. This exterior lighting application is respectful of adjacent neighbors.



EXAMPLE ENCOURAGED STYLES

DISCOURAGED

These homes all have exterior lighting which is too large for the application and incorrect fixtures for accent lighting of homes. Up-lighting is prohibited. Fixtures that direct or spill light onto adjacent lots or homes are also prohibited.



CHAPTER 4: DESIGN GUIDELINES – MASTER BUILDER SERIES

4.1.4. ADDRESS SIGNAGE

REQUIRED CHARACTERISTICS

Each residence in the Bretton Woods community will be required to install the approved standard address signage illustrated at right. The Bretton Woods Architectural Review Committee has established this standard for all residence types, including both Master Builder Series homes and Custom homes.

Signage shall be installed for maximum visibility from the street, integrated as part of the light standard as described in section 4.1.3. at or near the sidewalk entrance to the home. The lighted address signage shall be operated by a photoelectrical cell or similar device that enables the sign to remain lit throughout nighttime hours. The sign is sized appropriately and utilizes numeric font that can be easily read by individuals with average eyesight.

All address signage shall be reviewed and approved by the BWARC. Example images shown here provide guidance for design intent only.



EXAMPLE ENCOURAGED STYLES

CHAPTER 4: DESIGN GUIDELINES – MASTER BUILDER SERIES

4.2. COTTAGE HOMES

4.2.1. ELEVATIONS AND FLOOR PLANS: EXAMPLE 1 MODERN COTTAGE OPTION 1



This modern cottage blends traditional elements and simple forms to generate a contemporary yet authentic feel. Details include warm-toned stucco, brick siding, bold accent color on shutters and doors, and distinctive gable elements with accent details.

MODERN COTTAGE OPTION 2



This modern cottage blends traditional elements and simple forms to generate a contemporary yet authentic feel. Details include cool-toned stucco, accent stone, bold color on shutters and doors, and distinctive gable elements with accent details.

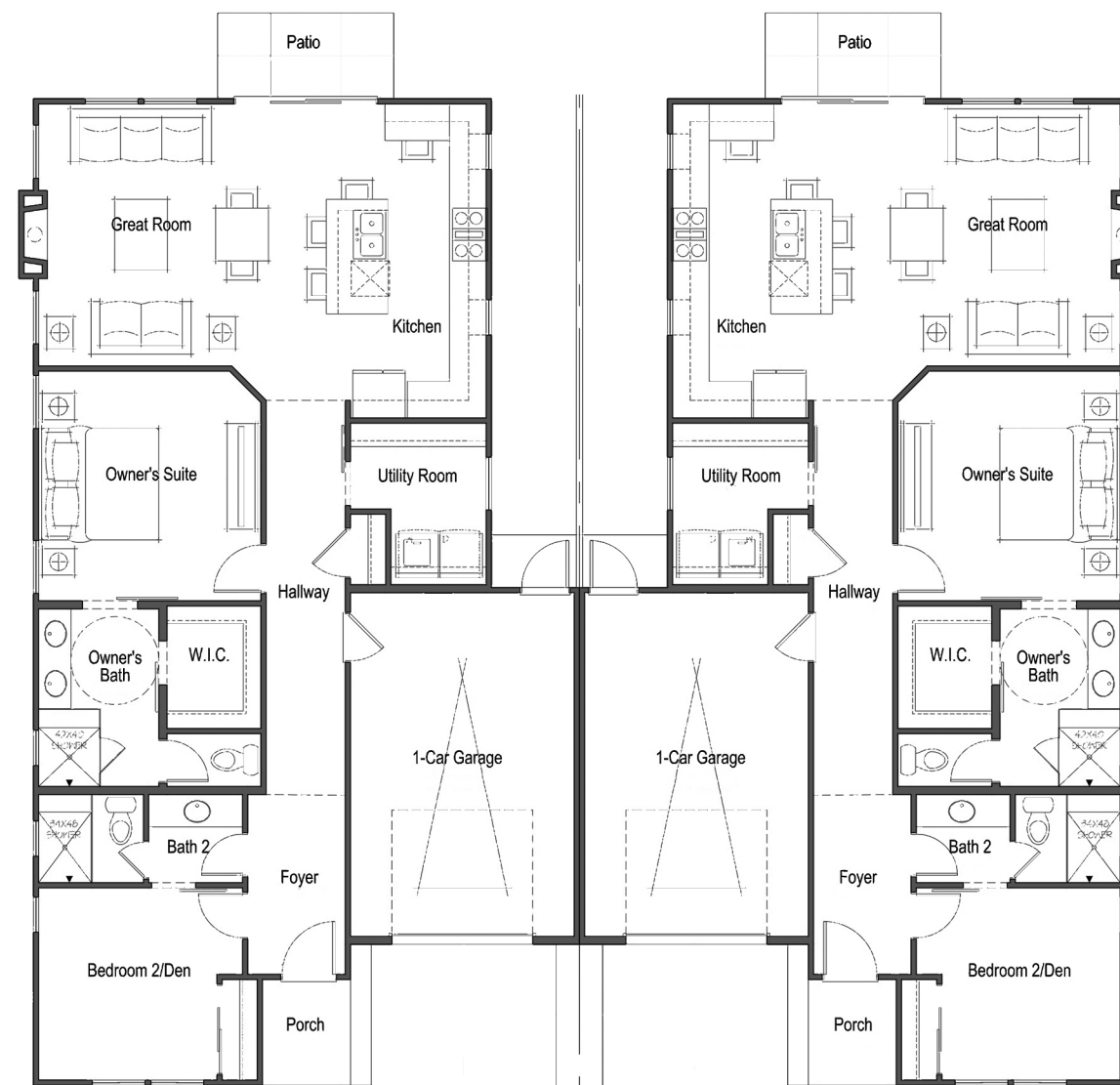

Size: 1,200 +/- square feet maximum
Configuration: 2 Bedrooms, 2 Bathrooms

CHAPTER 4: DESIGN GUIDELINES – MASTER BUILDER SERIES

4.3. BUNGALOW HOMES

4.3.1. ELEVATIONS AND FLOOR PLANS: EXAMPLE 1

CRAFTSMAN

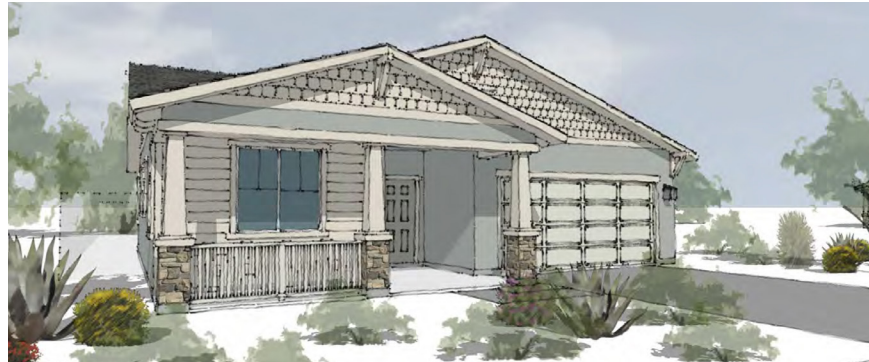

This style is characterized by a wide front porch, low-pitched gable roof elements with decorative brackets, a mix of lap and shingle siding, and thick or tapered columns with stone bases.

SPANISH



Arched windows and doorways are essential elements of the Spanish style. Stucco siding and clay tile roof and accent details are common, with inset entrances that provide protection from sun exposure.

MODERN



Strong verticality and intersecting planes at various pitches and angles are hallmarks of the modern elevation. Monoslope roofs and a mixture of natural and industrial elements complete the look.

- Prominent gables
- Concrete flat tiles
- 12" rakes & 12" eaves
- Decorative gable details & siding
- Wainscot with color blocking

- Prominent gables
- Concrete "S" tiles
- 0" rakes & 12" eaves
- Decorative gable details
- Decorative rafter tails

- Prominent hips
- Concrete "S" tiles
- 12" eaves
- Decorative wainscoting
- Decorative shutters

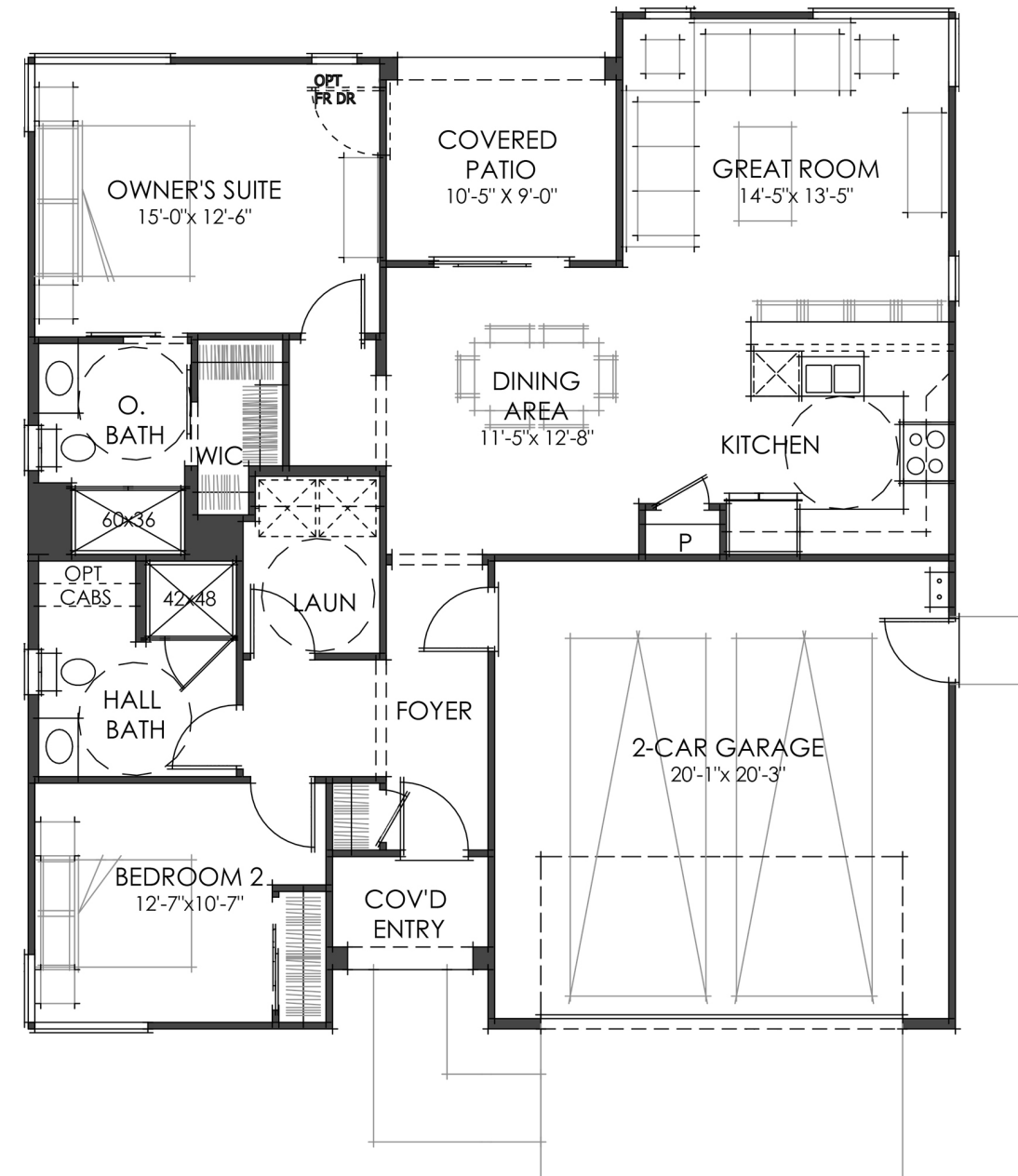

Size: 1,350 +/- square feet maximum
 Configuration: 2 Bedrooms, 2 Bathrooms

CHAPTER 4: DESIGN GUIDELINES – MASTER BUILDER SERIES

4.3.2. ELEVATIONS AND FLOOR PLANS: EXAMPLE 2

CRAFTSMAN



This style is characterized by a wide front porch, low-pitched gable roof elements with decorative brackets, a mix of lap and shingle siding, and thick or tapered columns with stone bases.

- Prominent gables
- Concrete flat tiles
- 12" rakes & 12" eaves
- Decorative gable details & siding
- Wainscot with color blocking

SPANISH



Arched windows and doorways are essential elements of the Spanish style. Stucco siding and clay tile roof and accent details are common, with inset entrances that provide protection from sun exposure.

- Prominent gables
- Concrete "S" tiles
- 0" rakes & 12" eaves
- Decorative gable details
- Decorative rafter tails

MODERN



Strong verticality and intersecting planes at various pitches and angles are hallmarks of the modern elevation. Monoslope roofs and a mixture of natural and industrial elements complete the look.

- Prominent hips
- Concrete "S" tiles
- 12" eaves
- Decorative wainscoting
- Decorative shutters

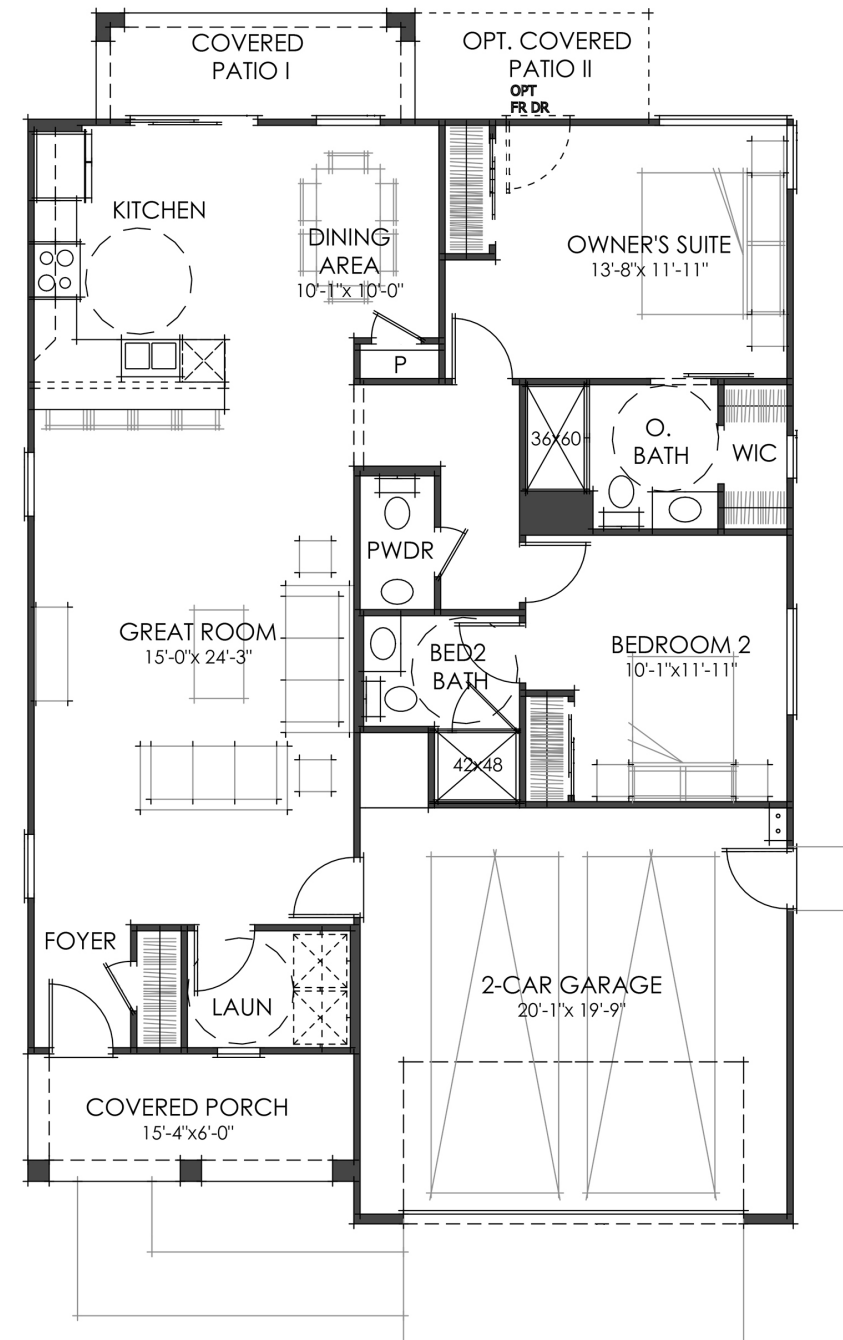

Size: 1,350 +/- square feet maximum
 Configuration: 2 Bedrooms, 2.5 Bathrooms

CHAPTER 4: DESIGN GUIDELINES – MASTER BUILDER SERIES

4.4. GREENWAY HOMES

4.4.1. ELEVATIONS AND FLOOR PLANS: EXAMPLE 1 CONTEMPORARY RANCH



Based on the low and wide street presence of traditional ranches, this contemporary style has a very low pitch hipped roof, balanced fenestration pattern and strong vertical and horizontal elements with distinct materials treatments.

MID-CENTURY RANCH



Uniquely angled rooflines are the hallmark of Mid-Century design. Simple detailing on primary massing elements is contrasted with rich natural texture on accent areas. Steel brackets, awnings or beams are characteristic of the style.

SPANISH MODERN



Taking cues from the historic Spanish style, this modern interpretation combines clean, white stucco with more industrial metal details, awnings and brackets to achieve a blended look of contemporary authenticity.

- Prominent hips
- Concrete flat tiles
- 12" eaves
- Decorative ship lap siding
- Decorative veneer

- Prominent gables
- Concrete flat tiles
- 12" rakes & 12" eaves
- Decorative gable details
- Decorative steel accents
- Decorative stone veneer

- Prominent gables
- Concrete flat tiles
- 0" rakes & 12" eaves
- Decorative gable details
- Decorative shutters

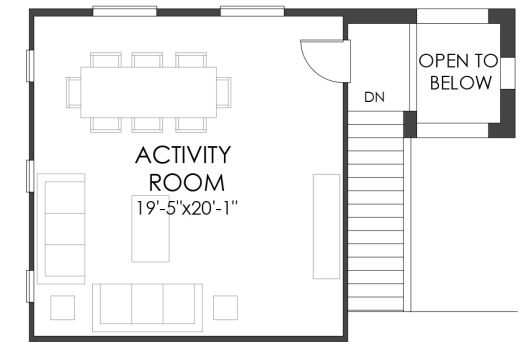
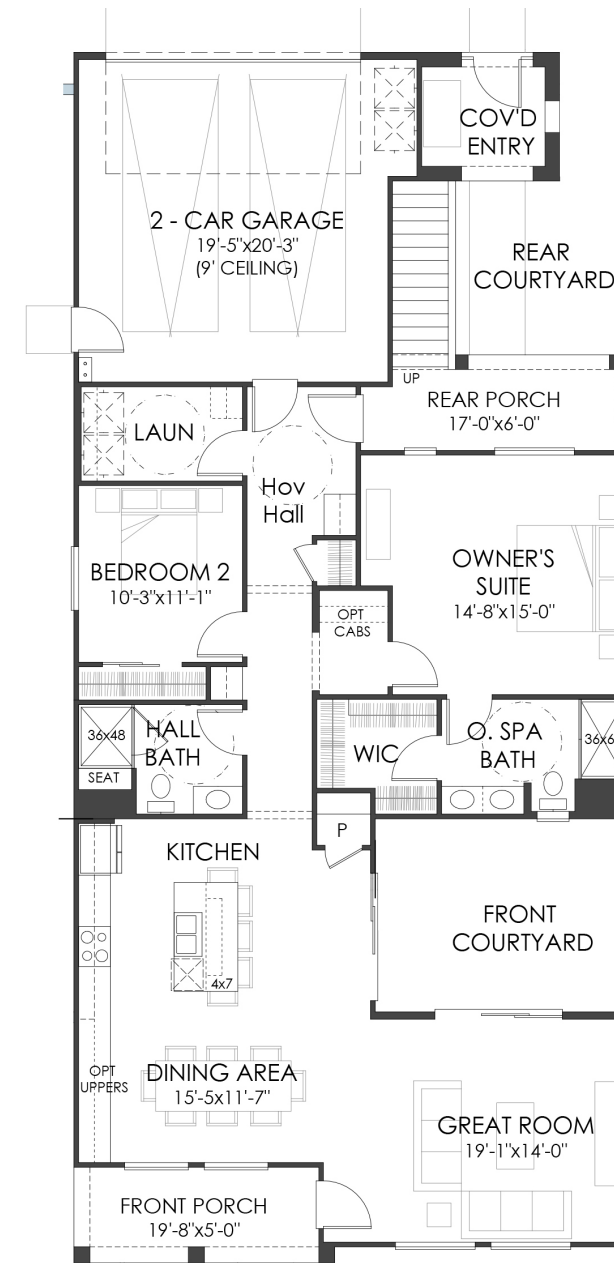

OPT. SECOND FLOOR -
ACTIVITY ROOM

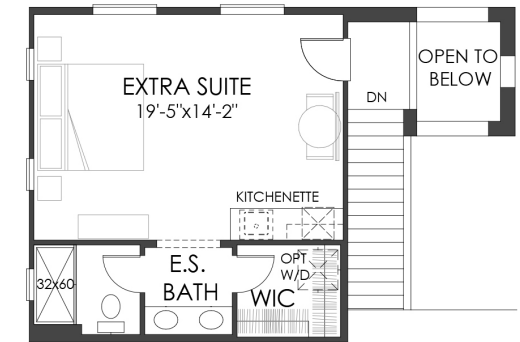

OPT. SECOND FLOOR -
EXTRA SUITE

Size: 1,875 +/- square feet maximum
Configuration: 2 Bedrooms, 2 Bathrooms
Options: 2nd Floor Activity Lounge; 2nd Floor Suite

CHAPTER 4: DESIGN GUIDELINES – MASTER BUILDER SERIES

4.4.1. ELEVATIONS AND FLOOR PLANS: EXAMPLE 1 (ADDITIONAL ELEVATIONS)

MODERN FARMHOUSE



FRONT (GREENWAY)

A twist on a rural American classic, this modern style emphasizes sleek materials in high contrast color, marked by simple massing with prominent gables. Dormers, vertical siding, stylistic shutters and a base of stone or brick complete the look.



REAR (STREETSIDE)

- Prominent gable
- Steel or concrete flat tile roof
- 12" rakes & 12" eaves
- Dormers and gable accents
- Stylistic shutters

MODERN CONTEMPORARY



FRONT (GREENWAY)

Distinctive box-like forms with flat roofs are staples of this modern style. Rustic wood-toned cladding juxtaposes sleek white stucco or paneled exteriors, and unique fenestration patterns create a bold look on both the front and rear of the home.



REAR (STREETSIDE)

- Flat roof
- 0" rakes & 0" eaves
- Large, modern windows
- Wood-look siding and stucco
- Unique corner glass

CHAPTER 4: DESIGN GUIDELINES – MASTER BUILDER SERIES

4.4.2. ELEVATIONS AND FLOOR PLANS: EXAMPLE 2

MID-CENTURY RANCH



Uniquely angled rooflines are the hallmark of Mid-Century design. Simple detailing on primary massing elements is contrasted with rich natural texture on accent areas. Steel brackets, awnings or beams are characteristic of the style.

SPANISH MODERN



Taking cues from the historic Spanish style, this modern interpretation combines clean, white stucco with more industrial metal details, awnings and brackets to achieve a blended look of contemporary authenticity.

- Prominent gables
- Concrete flat tiles
- 12"/24" rakes & 12" eaves
- Decorative gable details
- Decorative steel accents
- Decorative stone veneer

- Prominent gables
- Concrete flat tiles
- 10" rakes & 12" eaves
- Decorative gable details
- Decorative steel accents

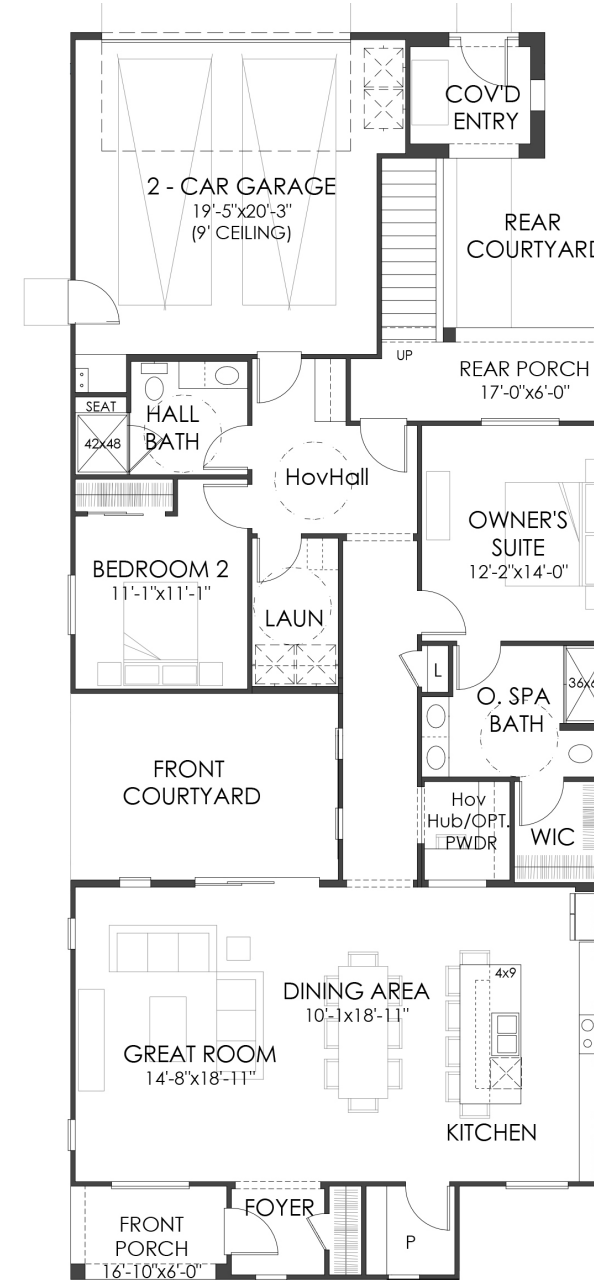

OPT. SECOND FLOOR - ACTIVITY ROOM

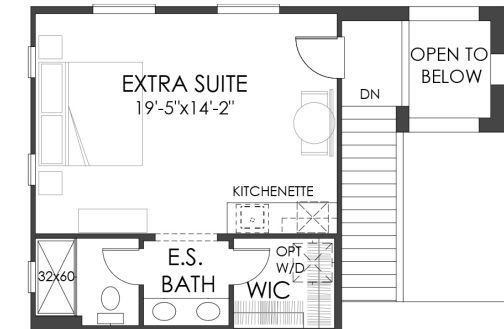

OPT. SECOND FLOOR - EXTRA SUITE

Size: 1,875 +/- square feet maximum
 Configuration: 2 Bedrooms, 2 Bathrooms
 Options: 2nd Floor Activity Lounge; 2nd Floor Suite

CHAPTER 4: DESIGN GUIDELINES – MASTER BUILDER SERIES

4.4.2. ELEVATIONS AND FLOOR PLANS: EXAMPLE 2 (ADDITIONAL ELEVATIONS)

MODERN FARMHOUSE



FRONT (GREENWAY)

A twist on a rural American classic, this modern style emphasizes sleek materials in high contrast color, marked by simple massing with prominent gables. Dormers, vertical siding, stylistic shutters and a base of stone or brick complete the look.



REAR (STREETSIDE)

- Prominent gables
- Steel or concrete flat tile roof
- 12" rakes & 12" eaves
- Brick accent and wainscot
- Horizontal & vertical siding

MODERN CONTEMPORARY



FRONT (GREENWAY)

Distinctive box-like forms with flat roofs are staples of this modern style. Rustic wood-toned cladding juxtaposes sleek white stucco or paneled exteriors, and unique fenestration patterns create a bold look on both the front and rear of the home.



REAR (STREETSIDE)

- Flat roof
- 0" rakes & 0" eaves
- Distinctive fixed glass and transoms
- Simple, unadorned cladding
- Unique corner glass

CHAPTER 4: DESIGN GUIDELINES – MASTER BUILDER SERIES

4.4.3. ELEVATIONS AND FLOOR PLANS: EXAMPLE 3

CONTEMPORARY RANCH



Based on the low and wide street presence of traditional ranches, this contemporary style has a very low pitch hipped roof, balanced fenestration pattern and strong vertical and horizontal elements with distinct materials treatments.

- Prominent hips
- Concrete flat tiles
- 12" eaves
- Decorative wainscoting
- Decorative stone veneer

MID-CENTURY RANCH



Uniquely angled rooflines are the hallmark of Mid-Century design. Simple detailing on primary massing elements is contrasted with rich natural texture on accent areas. Steel brackets, awnings or beams are characteristic of the style.

- Prominent gables
- Concrete flat tiles
- 12" rakes & 12" eaves
- Decorative steel accents
- Decorative stone veneer

SPANISH MODERN



Taking cues from the historic Spanish style, this modern interpretation combines clean, white stucco with more industrial metal details, awnings and brackets to achieve a blended look of contemporary authenticity.

- Prominent gables
- Concrete flat tiles
- 0" rakes & 12" eaves
- Decorative gable details
- Decorative shutters

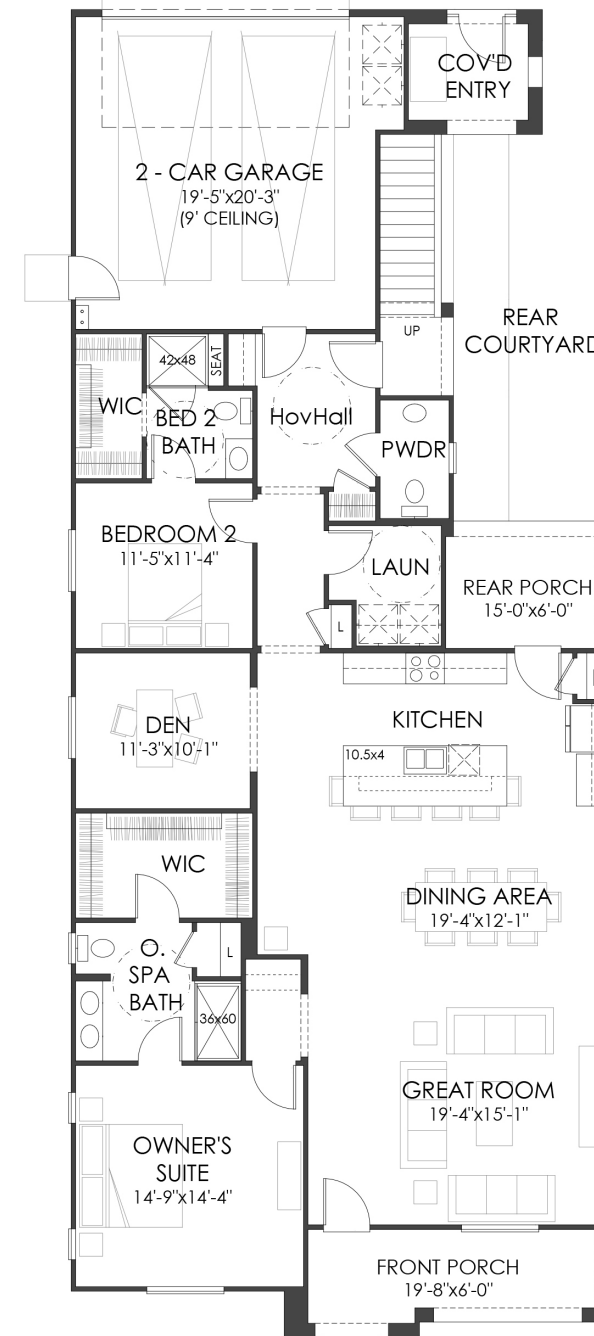

OPT. SECOND FLOOR - ACTIVITY ROOM

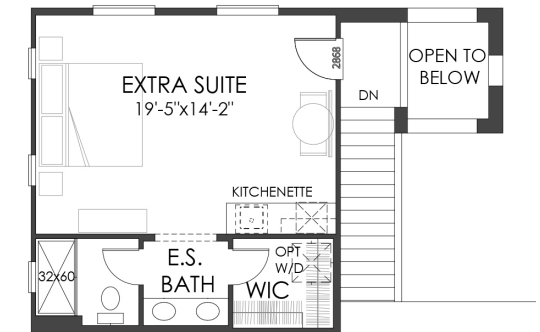

OPT. SECOND FLOOR - EXTRA SUITE

Size: 1,875 +/- square feet maximum
 Configuration: 2 Bedrooms, 2 Bathrooms, Den
 Options: 2nd Floor Activity Lounge; 2nd Floor Suite

CHAPTER 4: DESIGN GUIDELINES – MASTER BUILDER SERIES

4.4.3. ELEVATIONS AND FLOOR PLANS: EXAMPLE 3 (ADDITIONAL ELEVATIONS)

MODERN FARMHOUSE



FRONT (GREENWAY)

A twist on a rural American classic, this modern style emphasizes sleek materials in high contrast color, marked by simple massing with prominent gables. Dormers, vertical siding, stylistic shutters and a base of stone or brick complete the look.



REAR (STREETSIDE)

- Prominent gable
- Steel or concrete flat tile roof
- 12" rakes & 12" eaves
- Primary massing of stone
- Front porch focus on entry

MODERN CONTEMPORARY



FRONT (GREENWAY)

Distinctive box-like forms with flat roofs are staples of this modern style. Rustic wood-toned cladding juxtaposes sleek white stucco or paneled exteriors, and unique fenestration patterns create a bold look on both the front and rear of the home.



REAR (STREETSIDE)

- Flat roof
- 0" rakes & 0" eaves
- Prominent vertical entry focus
- Large, modern windows
- Wood-look accent siding

CHAPTER 5: DESIGN GUIDELINES – CUSTOM HOMES

5.1. CUSTOM HOME DESIGN PRINCIPLES

5.1.1. OVERVIEW

The architectural design standards for custom homes at Bretton Woods provide guidelines that are intended to establish an acceptable and authentic level of design. Variations on traditional styles are acceptable if developed within the spirit of these guidelines. Architectural styles of a non-descript character are not appropriate. All exterior elevation treatments require approval from the BWARC.

Appropriate elevation design and composition should reflect traditional and contemporary architectural styles found throughout the region. This standard does not rely on simple historic reproduction. Instead, style pages and illustrated details contained herein provide options to ensure consistent quality of character and detail for custom homes.

5.1.2. HOME TYPES AND SIZES

Type	Bedroom Count	Square Footage
Custom Homes: Single Story*	2/3+ Bedrooms	Determined by the Final Planned Development Standards

For additional details, refer to Section 6.1. “Final Planned Development Table”.

* A caregiver suite, visitor space or personal office is permitted as additional square footage within Custom Homes but shall be limited to the general area over the garage as a limited exception to the single story requirement.

DESIRABLE ARCHITECTURE



This modern farmhouse has balanced massing with a featured entrance and simple gable elements complemented by split pitches and metal awning roof details.



This one-story home has well-detailed masonry openings with a prominent entrance and simple massing. Color and materials are appropriate for the Spanish style.



This contemporary style home has a distinctive roofline and facade breaks highlighted by color and material changes. The front patio helps to capture outdoor space.

UNDESIRABLE ARCHITECTURE



Garage and driveway are too prominent. Porch and columns are not balanced with other massing. Material shifts are forced.



Elevation lacks symmetry and has no clearly defined style. Shutters are inappropriately sized for window openings.



Paired windows are detailed improperly. The garage is too prominent in the elevation.

CHAPTER 5: DESIGN GUIDELINES – CUSTOM HOMES

5.2. CUSTOM HOME DESIGN AND GUIDELINES

Custom homes at Bretton Woods should adhere to the following design standards and guidelines to ensure approval. The Bretton Woods Architectural Review Committee (BWARC) shall establish and amend its own rules and regulations with regards to membership, meetings, procedural matters and revisions to these Design Standards.

- Plans that are compatible with the “Aging in Place” concept are strongly encouraged. Maximum height of buildings to be constructed shall not exceed one story except generally over the garage area may be two stories (maximum height TBD) unless the BWARC approves of deviations in height above said maximum and must be designed and constructed to harmonize with the surroundings, including pre-existing homes in the neighborhood. All construction is to be carried out as per standard building code practices and as per city/county code and obtain all permits and approvals as required. Refer to zoning section for height.
- All residences shall be sited according to the lot plan for the specific lot. Setback diagrams are provided in section 6.2. Bretton Woods strongly encourages staggered setbacks for houses to the greatest extent possible considering the locations of homes already built or planned on adjacent lots.
- One caregiver suite will be allowed per lot where applicable. The caregiver suite will be allowed to have a bathroom (toilet, sink, bathtub and/or shower) facility and one kitchen with cooking facilities. The caregiver suite shall not be flush with garage door wall and shall be set back to provide architectural articulation.
- Garage and residential house frontage shall have a minimum massing off-set of 3 (three) to 5 (five) feet.
- Each lot or residence owner shall submit landscape plans to the BWARC for review and approval as an initial step prior to submitting to the city with the building permit application. Planting minimums must meet Bretton Woods landscape requirements as set forth in section 3.3. Front and rear landscaping shall be installed prior to occupancy, weather permitting and at the discretion of the BWARC. All spec homes shall include front and rear yard landscaping as part of the sale.
- No fencing shall be installed over thirty-six (36) inches in height in the front yard. Side yard fencing and gates and rear yard fencing shall be 6’ in height.
- Fences and fencing materials are subject to the approval of the BWARC which has established uniform design criteria for all lots (see section 3.4.4.). Fences shall be designed for identical looks on both sides. Wing fences are not permitted to extend within five (5) feet of the front facing residence wall. No alternating material, fascia, or appearance is allowed. Refer to examples of acceptable fencing as provided in section 3.4.4. which highlight specific requirements, such as steel fence posts and wood wraps.
- No cyclone fencing and no structures with metal siding or solid (non-transparent) metal fences of any type are allowed, with the exception of wrought iron style fencing, to be constructed on any lot.
- All homes shall have a minimum of one driveway or sidewalk light mounted on a standard or decorative platform/wall at or near the driveway or sidewalk entrance nearest the street which includes the address plaque. The light shall be sufficient in size to illuminate the driveway entrance area and be operated by a photoelectric cell or similar device in order to have it operating during nighttime hours. Specific lighting design details are provided in section 5.2.1.
- All residences shall have an approved numerical plaque clearly indicating the property address. The signs are to be placed on the light standard as described in section 5.2.2. at or near the sidewalk entrance to the home so as to be clearly visible from the street. The light standard shall be operated by a photoelectrical cell or similar device in order to have it lit during nighttime hours, and be easily visible from the street.
- All roofs including garages and carports shall have gutters and downspouts connected to one or more underground pipes that direct water to side yards and streetside gutters and away from the house foundation. Specific detail about water management requirements is provided in section 3.3.4.
- All composition-roofing materials shall be earth tones. No green or red-colored composition roofing materials are permitted. All roofing materials and styles are subject to the approval of the ACC and shall carry a 40-year minimum warranty. Examples of acceptable materials are included in section 5.3.2.
- Siding material must be approved by the BWARC and must be a consistent material throughout the exterior of the residence and any ancillary structures.
- Foundation and slabs shall comply with the Preliminary Design Memorandum and Geotechnical Investigation issued by Geocon Consultants, Inc., dated March 8, 2019, and August 2019, respectively or as amended.
- Each residence shall have a minimum of two (2) enclosed off-street parking spaces, whether attached to or detached from the residence. Garage door shall not be shiny. Maximum driveway widths shall be eighteen (18) feet at the back of walk and constructed to the specifications set forth in the Geotechnical Investigation issued by Geocon Consultants, Inc., dated August 2019 or as amended. Driveways to be constructed to standards subject to approval by the BWARC.
- Entry walks to individual residences shall be separated from the driveway by landscaped areas, will be constructed of concrete and will meander through the lot.
- All units shall have an area designated for storage of trash and recycling containers. This area shall be three (3) feet by eight (8) feet concrete pad located adjacent to the house or garage. If located on the exterior of the building, this area shall be landscaped or screened from view from the street. Location of pad to be shown on all site plans subject to approval by the BWARC.

CHAPTER 5: DESIGN GUIDELINES – CUSTOM HOMES

5.2.1. EXTERIOR LIGHTING AT DWELLING

REQUIRED CHARACTERISTICS

- Exterior residential lighting shall convey a warm, inviting atmosphere and aid in providing night time security without annoying others. Selection and placement of fixtures, and selection of light source types, should be done with care. Exterior illumination of architectural features such as columns, entries, chimneys and landscape features is encouraged.
- Each custom lot will install a Hammond Lantern Post w/ Sign Arm (#795425, example below) in the front yard. Address signs will be illuminated. Ground lighting or decorative light fixtures are encouraged. Decorative fixtures shall be of high quality materials and workmanship and be in scale and style with the home.
- Exterior lighting shall be installed in a manner that is not unsightly or the cause of unnecessary light pollution, distraction or nuisance.
- All lighting shall conform to the 2019 California Electrical Code and the California Energy Code (or more current versions of these Code documents, when available).
- All lighting shall be reviewed and approved by the BWARC. Example images shown here provide guidance for design intent only.

ENCOURAGED

These homes all have exterior lighting which is scaled for the application. Up-lighting and wall applied fixtures are placed correctly. This exterior lighting application is respectful of adjacent neighbors.

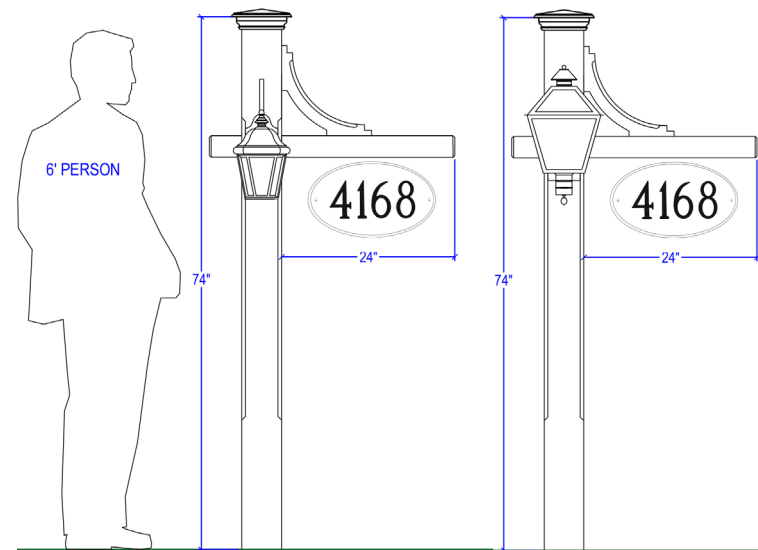

EXAMPLE ENCOURAGED STYLES: AT DWELLING

EXAMPLE ENCOURAGED STYLES: FRONT YARD

PROHIBITED

These homes all have exterior lighting which is too large for the application and incorrect fixtures for accent lighting of homes. Exterior lighting shall be appropriately sized for the specific location and architectural style while being respectful of neighbors.

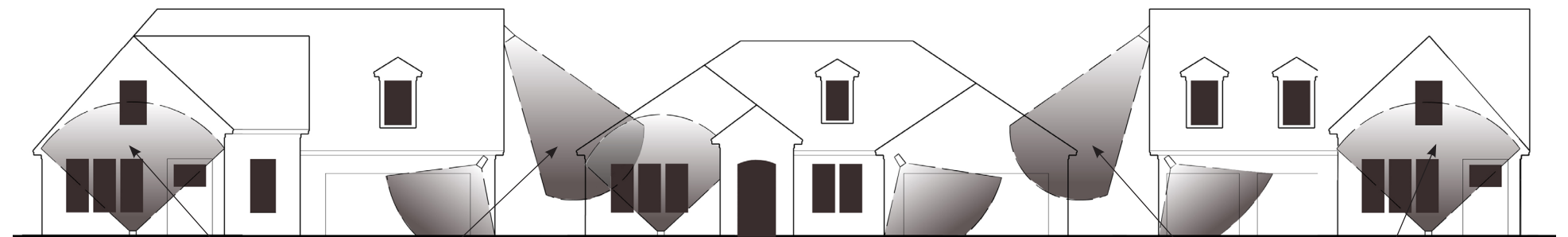

PROHIBITED

PROHIBITED

CHAPTER 5: DESIGN GUIDELINES – CUSTOM HOMES

5.2.2. ADDRESS SIGNAGE

REQUIRED CHARACTERISTICS

Each residence in the Bretton Woods community will be required to install the approved standard address signage illustrated at top and middle right. The Bretton Woods Architectural Review Committee has established this standard for all residence types, including both Master Builder Series homes and Custom homes.

Signage shall be installed for maximum visibility from the street, integrated as part of the light standard as described in section 5.2.1. at or near the sidewalk entrance to the home. The lighted address signage shall be operated by a photoelectrical cell or similar device that enables the sign to remain lit throughout nighttime hours. The sign is sized appropriately and utilizes numeric font that can be easily read by individuals with average eyesight.

In addition to on-house signage, Custom homes will be required to install street-side address plaques. These plaques will hang from the front yard lantern post and will be illuminated by this lantern. The required plaque style is the Montague Metal Classic Oval Standard Address Sign Wall Plate, illustrated at bottom right.

All address signage shall be reviewed and approved by the BWARC. Example images shown here provide guidance for design intent only.



**REQUIRED ADDRESS SIGNAGE:
FRONT YARD LANTERN SIGN ARM**

CHAPTER 5: DESIGN GUIDELINES – CUSTOM HOMES

5.3. MATERIALS AND TREATMENTS

5.3.1. OVERALL DESIGN

REQUIRED CHARACTERISTICS

- Authentic use of exterior materials adds richness and character to homes appearance.
- The use of color and various materials such as siding, stucco, brick and stone should be used to create interest and diversity along the streetscape. Final exterior color selections are subject to review and approval by the BWARC.
- Architectural materials, trims and details shall be used on all sides of the home.
- Use of material changes to break-up building form and create interest on the façade.
- Roof materials must be architectural grade composite shingles, clay, concrete or metal and appropriate to the style of the home.
- Materials can not terminate at outside corners. They must terminate at inside corners or in a historically appropriate fashion.
- Entry elements should vary in height and proportion.
- Windows, doors and openings shall be detailed, sized and proportioned appropriately for the architectural style.

PROHIBITED

- Styrofoam trim detailing is prohibited.

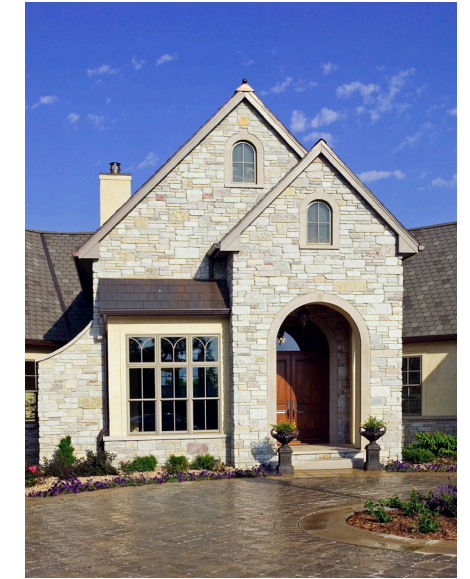

CHAPTER 5: DESIGN GUIDELINES – CUSTOM HOMES

5.3. MATERIALS AND TREATMENTS

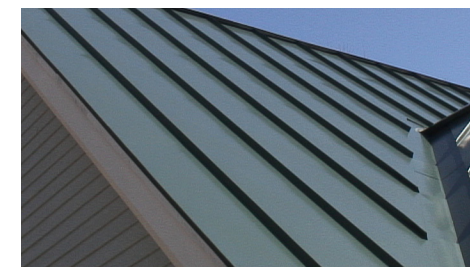
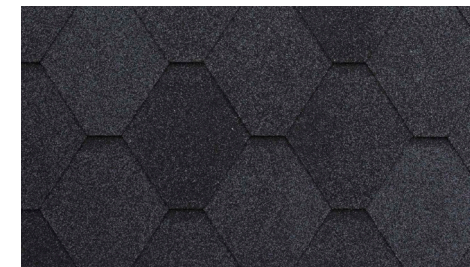
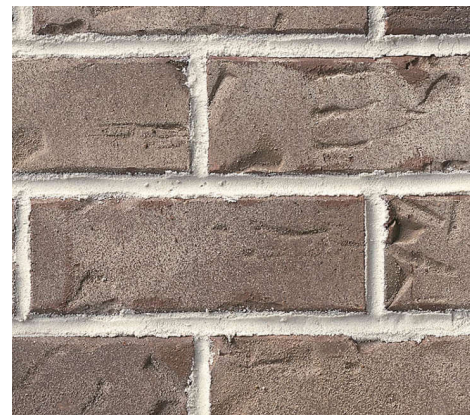
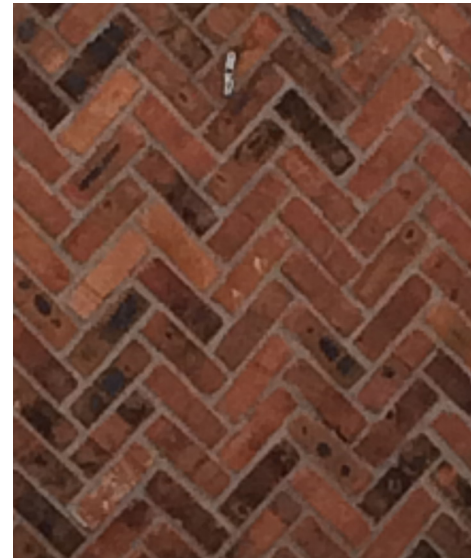

5.3.2. BUILDING MATERIALS

REQUIRED CHARACTERISTICS

- Asphalt shingle roof materials must be 40 year shadow profile architectural dimensional grade composite shingles appropriate to the style of the home. Diamond tab and oversize tab shingles are permitted. Color range shall be black to brown to gray (i.e. weathered wood) with slight color variation allowed in range of color approved. Standing seam metal, clay tile, cementitious tile or simulated slate are permitted when appropriate to the style of the home and shall be in earth tone colors.
- Four sides of the home on the first and second story of front elevation shall have brick, natural stone, painted brick, slurried brick, multiple brick colors, cast stone, and stucco on exterior walls backing to or siding open space areas and major thoroughfares. Individual plan approval shall be at the discretion of the BWARC.
- Stucco must be triple layer. Textured stucco or plaster finishes may be allowed if architecturally and stylistically appropriate at the discretion of the BWARC.
- Cementitious siding is permitted.
- Materials cannot terminate at outside corners. They must terminate at inside corners or in a historically appropriate fashion. Return 3'-0" or stop at a logical location.
- Half-round gutter and downspouts are encouraged. Scuppers are permitted. Ogee gutter and downspouts are permitted.
- Windows shall be vertically proportioned single or double-hung windows. No metal windows are permitted. Brick, cast stone trim, brick mould or wood trim is required. Bay windows are encouraged.

PROHIBITED

- Course finished stucco or plaster is prohibited.

CHAPTER 5: DESIGN GUIDELINES – CUSTOM HOMES

5.3. MATERIALS AND TREATMENTS



5.3.3. EXTERIOR STRUCTURE MATERIALS

REQUIRED CHARACTERISTICS

- Windows, doors and openings shall be detailed, sized and proportioned appropriately for the architectural style.
- A minimum of an eight foot tall door is required at main home entrance and may be paired as applicable to the proposed style with sidelights. Glass is permitted in entry doors in keeping with elements of primary structure. Six foot eight inch tall entry doors are not permitted.
- All window muntins shall be vertical in proportion.
- Shutters shall match the proportion of windows they serve and shall appear to be operable with applicable hardware.
- Roof overhangs or door insets are encouraged at the garage façade.
- Garage doors shall be carriage style single bay (8' or 16' wide) having a swing out appearance including hardware to appear operable. Garage doors shall be insulated steel smooth finish or wood grain appearance. Doors may be wood clad.

PROHIBITED

- Styrofoam trim detailing is prohibited.

CHAPTER 5: DESIGN GUIDELINES – CUSTOM HOMES

5.3. MATERIALS AND TREATMENTS

5.3.4. EXTERIOR STRUCTURE TREATMENTS

REQUIRED CHARACTERISTICS

- Minimum of 8:12 to maximum of 16:12 and appropriate to the character of the elevation. Porch roofs may be shallow pitches. Refer to graphic example.
- A minimum nine foot plate height is required on front elevation and ten foot plate height is encouraged.
- Chimneys are encouraged as a design element. Chimneys shall be stone, brick or stucco in material. Vent pipes or stacks are to be visually minimized from any street and must be vertical. Cementitious siding chimneys are permitted.
- Eaves can be detailed either with open rafters or “boxed” soffits and feature either square, plumb or scrolled rafter tails. Eaves shall have material returns along the exterior wall.
- Up to three materials are allowed on primary structure.
- Special window shapes and sizes are allowed as architectural features where approved by the BWARC.
- Window openings and muntins shall be vertical in proportion with two times the height over width.
- Shutters are permitted with hardware to appear operable. Shutters must be proportional to window openings.

PROHIBITED

- Styrofoam trim detailing is prohibited.

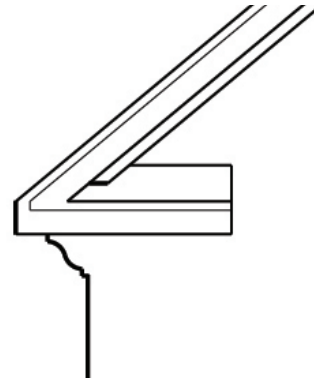

STUCCO DETAIL AT EAVE WITH RETURN

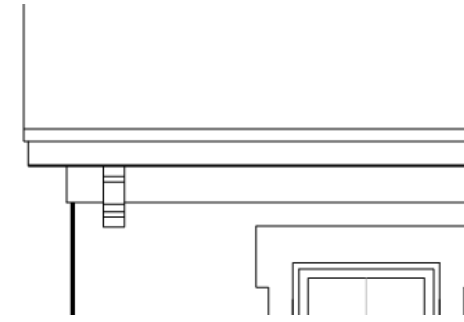

EAVE WITH BRACKET AND FRIEZE BOARD

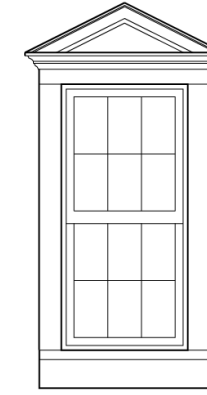

DORMER

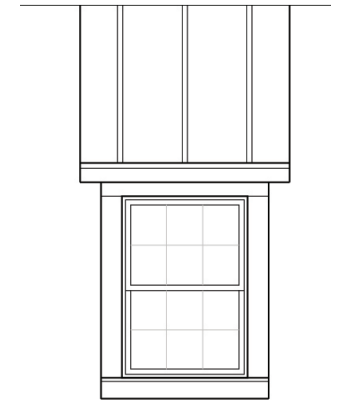

SHED DORMER

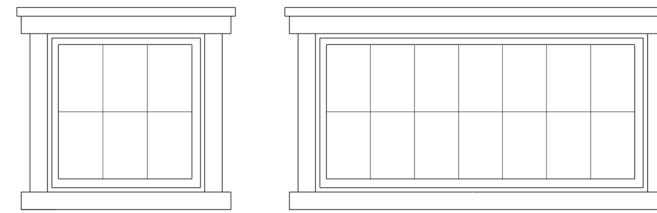

TRANSOM OR CLERESTORY

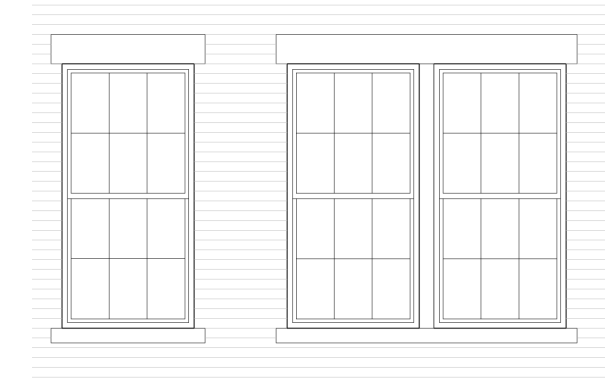

SINGLE OR DOUBLE-HUNG WINDOWS SINGLE OR PAIRED

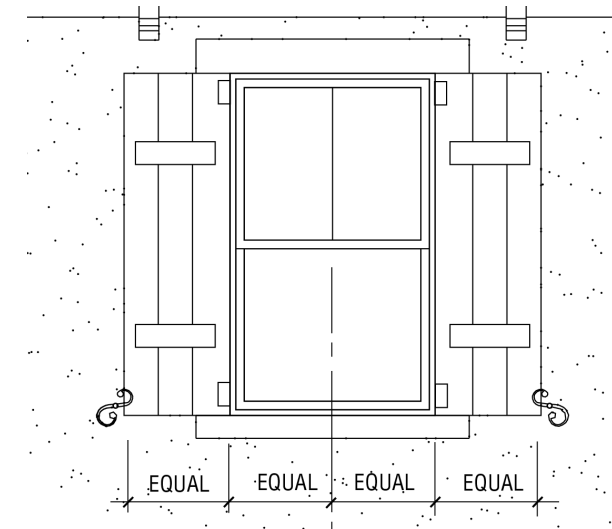

SHUTTERS

CHAPTER 5: DESIGN GUIDELINES – CUSTOM HOMES

5.3. MATERIALS AND TREATMENTS

5.3.5. ELEMENT MATERIALS AND CONFIGURATIONS

ELEMENT	MATERIALS AND CONFIGURATIONS
Roof Pitch	Minimum of 4:12 to maximum of 8:12 and appropriate to the character of the elevation. Porch roofs may be shallow pitches. Refer to graphic example.
Roof Materials	40 year shadow profile architectural dimensional grade composite shingles in conventional or diagonal shape, oversized tab, standing seam metal, clay tile, cementitious shingle, artificial slate.
Chimneys and roof vents	Chimneys are required to be stone, brick or stucco material and encouraged as design element. Cementitious siding chimneys are permitted. Vent pipes or stacks are to be visually minimized from any street and must be vertical.
Garage	Garages are encouraged to be off-set a minimum of 3 (three) to 5 (five) feet from primary front facade. A roof overhang or door inset is encouraged.
Garage Doors	8' or 16' metal carriage door with lites are permitted. Doors shall have hardware to appear operable. Doors may be wood clad or simulated wood. Garage doors on rear loaded garages accessed from alleys shall have no hardware and shall be insulated metal panel.
Front Porch	Porch depth shall be a minimum of 7' and porch width shall be a minimum of 10' per section 4.07.16 B of the zoning code. Concrete is required. Exterior tile, brick and stone are also permitted.
Shutters	Shutters permitted with hardware required to appear operable. Shutters must be proportional to window openings.
Exterior Wall Materials	Four sides of the home on the first and second story of front elevation shall have brick, natural stone, painted brick, slurried brick, multiple brick colors, cast stone, and stucco on exterior walls. Brick shall be above stone in the facade. Brick shall be common bond with rowlock sills and basket weave, herringbone, diaper pattern, corbelling and other patterns or color accents are encouraged. Cementitious siding is permitted.
Lighting	Lighting should be of appropriate size and consistent with the character of the elevation.
Leadwalks	4' wide minimum. Brick, stone, pavers or concrete pattern accents are required. Color to match driveway. Meandering.
Driveways or Circle Drives	Brick, stone, pavers, crushed granite, or concrete pattern accents are required. Circular driveways are permitted.
Energy Requirements	All homes must meet the current CEC and City of Davis requirements.
Additional Requirements:	Side and rear elevation conditions with visible lot situations require elevation design attention to create pleasing façades and details. Stylistic elevations are permitted and encouraged. Preliminary approval required.

Compliance is at the discretion of the BWARC.

CHAPTER 6: FINAL PLANNED DEVELOPMENT

6.1. FINAL PLANNED DEVELOPMENT TABLE

TYPICAL FLOOR PLANS	G-PLAN (INTERIOR)	G-PLAN (CORNER)	B-PLAN (INTERIOR)	B-PLAN (CORNER)	CUSTOM	C-PLAN (INTERIOR)	C-PLAN (CORNER)	SENIOR AFFORDABLE	SPECIALIZED SENIOR CARE
1ST STORY PRIMARY HABITABLE SPACE (±SF, MAX)	1,875	1,875	1,350	1,350	****	1,200	1,200	-	-
GARAGE (±SF, MAX)	450	450	450	450	****	300	300	-	-
CAREGIVER SPACE (±SF, MAX) ***	600	600	600	600	600	-	-	-	-
TOTAL UNIT AREA (±SF, MAX)	2,925	2,925	2,400	2,400	****	1,500	1,500	-	-
OPEN SPACE (±SF)	N/A	N/A	N/A	N/A	N/A	N/A	N/A	25%	25%
LOT AREA (±SF, MIN)	4,250	4,700	3,600	3,600	4,900	2,600	2,600	-	-
LOT COVERAGE (% MAX)	55%	55%	50%	50%	60%	60%	60%	N/A	N/A
FLOOR AREA RATIO (MAX)	0.7	0.7	0.67	0.67	0.75	0.60	0.60	1.4	SEE NOTE 8
BUILDING SETBACKS (FT, MIN)									
FRONT	4'	4'	16'	16'	10' (20')*	16' (18')*	16' (18')*	25' (SPIRIT ST)	25' (SPIRIT ST)
REAR	4'	4'	10'	10'	13'	5'	5'	25' (AG BUFFER)	25' (RISLING ST)
LEFT SIDE	5'	10'	5'	9'	5'	5'	10'	30' (COVELL)	3-STORY 60': 4-STORY 75' (NORTH PL)
RIGHT SIDE	5'	5'	5'	5'	5'	0**	0**	3-STORY 60': 4-STORY 75' (NORTH PL)	30' (COVELL)
BUILDING HEIGHT (FT, MAX)	30'	30'	25'	25'	30'	25'	25'	50'	50'
PARKING (GARAGE+RESERVED)	2	2	2	2	2	1	1	-	-

* (GARAGE SETBACK)

** REFER TO NOTE 7 BELOW

*** REFER TO NOTE 2 BELOW

**** REFER TO NOTE 9 BELOW

NOTES:

- 2ND STORY MINIMUM SETBACK DIMENSIONS ARE THE SAME AS 1ST STORY, EXCEPT WHERE NOTED IN PARENTHESIS.
- A CAREGIVER SUITE, VISITOR SPACE OR PERSONAL OFFICE IS PERMITTED FOR THE GREENWAY HOMES AND THE CUSTOM HOMES BUT SHALL BE LIMITED TO THE GENERAL AREA OVER THE GARAGE AS A LIMITED EXCEPTION TO THE SINGLE STORY REQUIREMENT. A STAND-ALONE CAREGIVER / ACCESSORY DWELLING UNIT IS PERMITTED FOR THE BUNGALOWS.
- "LOT COVERAGE" IS DEFINED AS GROUND FLOOR BUILDING AREA, INCLUDING GARAGE AND PORCH, DIVIDED BY THE LOT SIZE.
- "FLOOR AREA RATIO" IS DEFINED AS THE SQUARE FOOTAGE OF THE BUILDING, DIVIDED BY THE LOT SIZE.
- "OPEN SPACE" FOR ALL PLANS IS DEFINED AS THE LOT AREA THAT HAS A MINIMUM DIMENSION OF 12'X12', NOT INCLUDING UNFENCED FRONT YARD OR ANY DRIVEWAY/PARKING AREA.
- "TOTAL UNIT AREA" IS DEFINED AS THE SUM OF THE HABITABLE AREA AND THE GARAGE.
- ZERO LOT LINE IS ON COMMON WALL FOR DUPLEX UNITS.
- SEE DESIGN GUIDELINES - SECTION 7.2 FOR ADDITIONAL INFORMATION ON FLOOR AREA RATIO.
- THE SIZE OF THE CUSTOM HOMES SHALL BE DETERMINED BY THE FINAL PLANNED DEVELOPMENT STANDARDS INDICATED HEREIN.

CHAPTER 6: FINAL PLANNED DEVELOPMENT

6.2. SINGLE FAMILY HOMES LOT SETBACK DIAGRAMS



CHAPTER 6: FINAL PLANNED DEVELOPMENT

6.2. SINGLE FAMILY HOMES LOT SETBACK DIAGRAMS

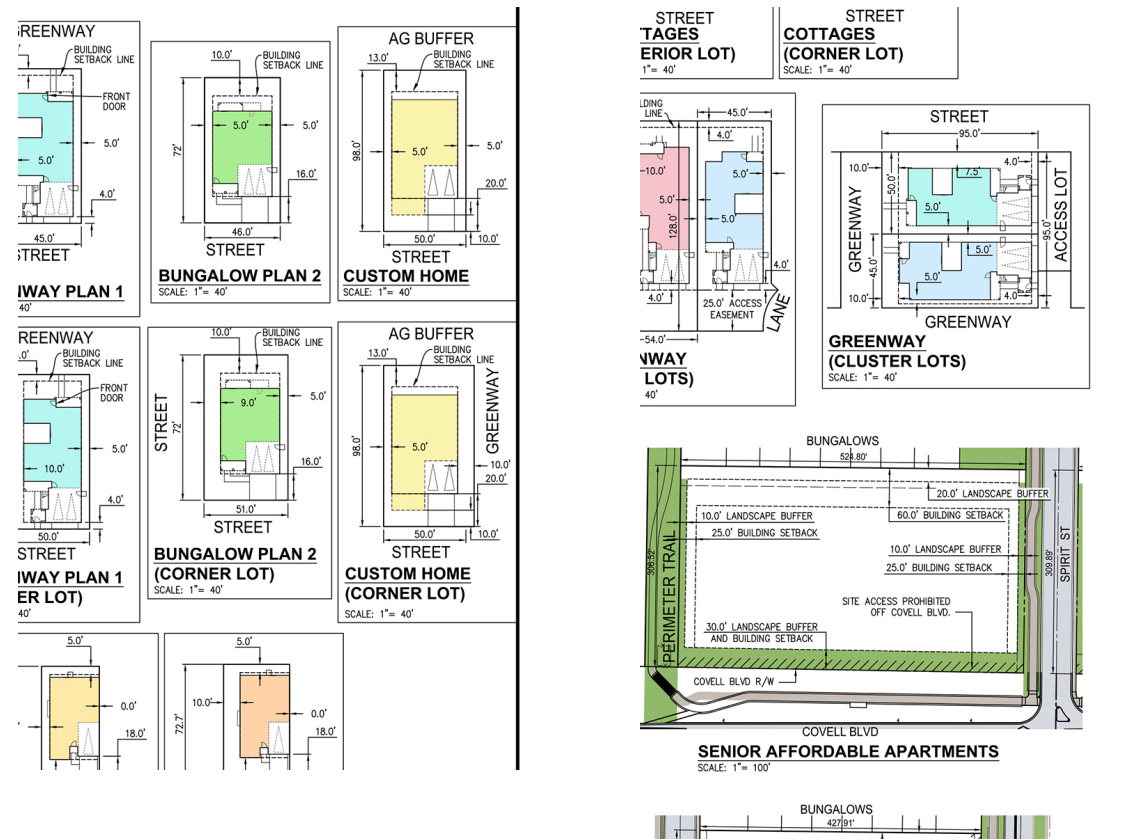
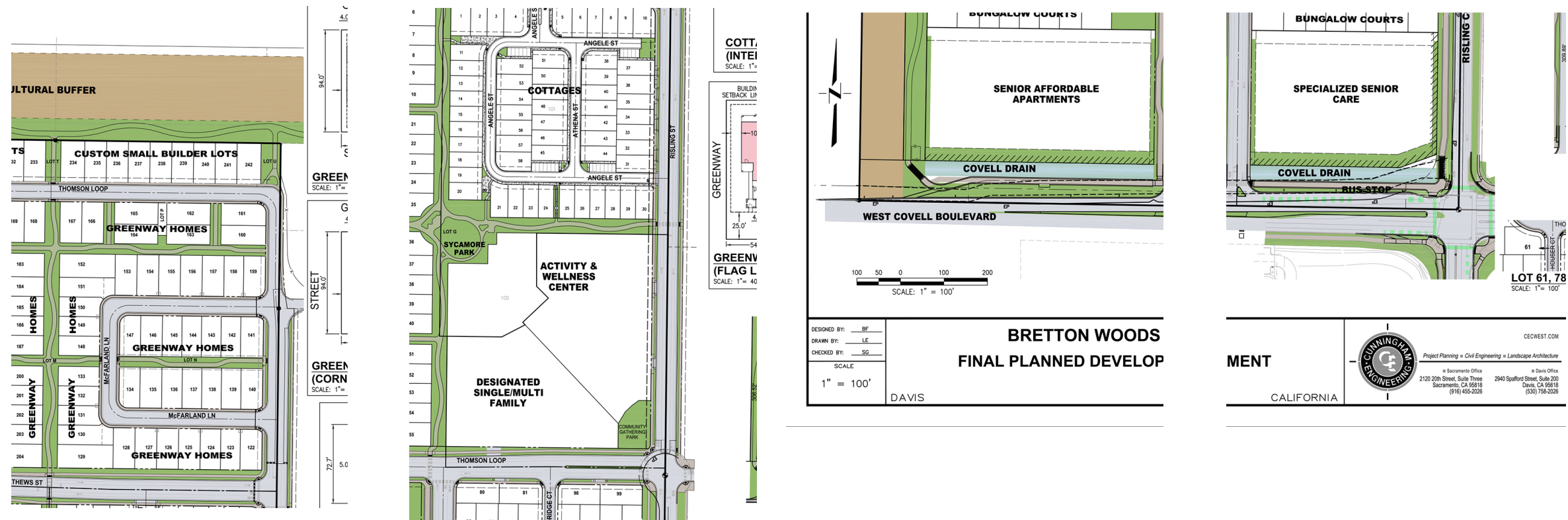

CHAPTER 6: FINAL PLANNED DEVELOPMENT

6.3. SENIOR AFFORDABLE APARTMENTS

6.3.1. UNIT TYPES AND SIZES

Type	Bedroom Count	Square Footage
Senior Apartments	1-2 Bedrooms	1,000 s.f. maximum
Senior Affordable Apartments	1-2 Bedrooms	1,000 s.f. maximum

For additional details, refer to Section 6.1. "Final Planned Development Table".

6.3.2. SETBACKS

BUILDING SETBACKS:

- Front (Spirit St.): 25'-0"
- Rear (Ag Buffer): 25'-0"
- Left Side (Covell Blvd.): 30'-0"
- Right Side (North Pl.): 75'-0" (4-story building); 60'-0" (3-story building)

LANDSCAPE SETBACKS:

- Front (Spirit St.): 10'-0"
- Rear (Risling St.): 10'-0"
- Left Side (North Pl.): 20'-0" min.
- Right Side (Covell Blvd.): 30'-0"

Landscape setbacks are included within the building setbacks listed above and shall include no hardscape.

HEIGHT (MAX):

- Multi-story buildings: 4 stories, 50'-0" max height a.f.f.; 3 stories, 45'-0" max height a.f.f.

PARKING:

- All parking and shade requirements to be per City of Davis Municipal Code Chapter 40, Article 40.25.070.

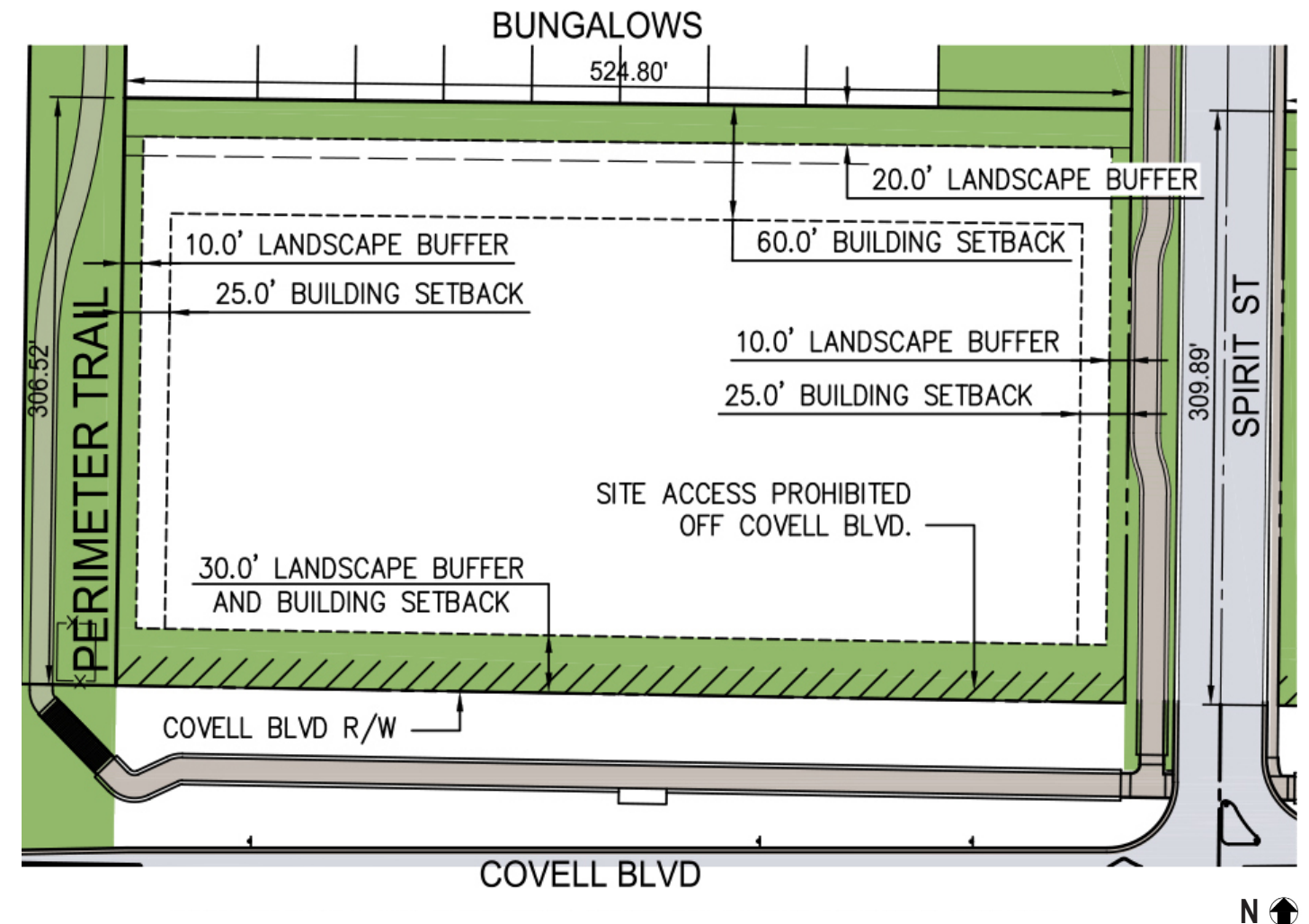

CHAPTER 6: FINAL PLANNED DEVELOPMENT

6.4. SPECIALIZED SENIOR CARE

The purpose of this section is to provide guidance for the specialized senior care housing, which may include assisted living, memory care, or other senior care uses, within the Planned Development of Bretton Woods.

For the purposes of the Planned Development of Bretton Woods and City of Davis Municipal Code Chapter 40, Section 40.03.020, such specialized senior care housing may consist of either of the following:

- Group Care Home: Residential dwelling units licensed as residential care facilities for the elderly that provide housing for six or fewer residents. Group care homes may be stacked, but must be one level per unit. Group care homes shall be between 1,000 square feet and 2,000 square feet per unit.
- Supportive Housing: Multi-story residential facilities licensed as residential care facilities for the elderly providing housing for six or more residents with shared common kitchen and activity areas.

6.4.1. SETBACKS

MULTI-STORY BUILDING SETBACKS:

- Front (Spirit St.): 25'-0"
- Rear (Risling St.): 25'-0"
- Left Side (North Pl.): 75'-0" (4-story building); 60'-0" (3-story building)
- Right Side (Covell Blvd.): 30'-0"

Multi-story buildings should be pushed to the street side along Covell Blvd. and can be built adjoining the 30'-0" landscape setback.

Multi-story buildings shall incorporate 4-sided architecture.

LANDSCAPE SETBACK:

- Front (Spirit St.): 10'-0"
- Rear (Risling St.): 10'-0"
- Left Side (North Pl.): 20'-0"
- Right Side (Covell Blvd.): 30'-0"

Landscape setbacks are included within the building setbacks listed above and shall include no impermeable hardscape. Landscape setbacks may not include parking for any motor vehicles, but may include walking paths, sitting areas or compatible recreation areas such as a putting green or bocce ball court.

Minimum building setbacks for single story housing shall be the same as the Landscape setbacks.

HEIGHT (MAX):

- Multi-story buildings: 4 stories, 50'-0" max height a.f.f.; 3 stories, 45'-0" max height a.f.f.
- Single story buildings: 21'-0" max height a.f.f.

FLOOR AREA RATIO (FAR):

Up to fifty percent plus up to five hundred square feet per supportive housing unit for any garage or carport floor area.

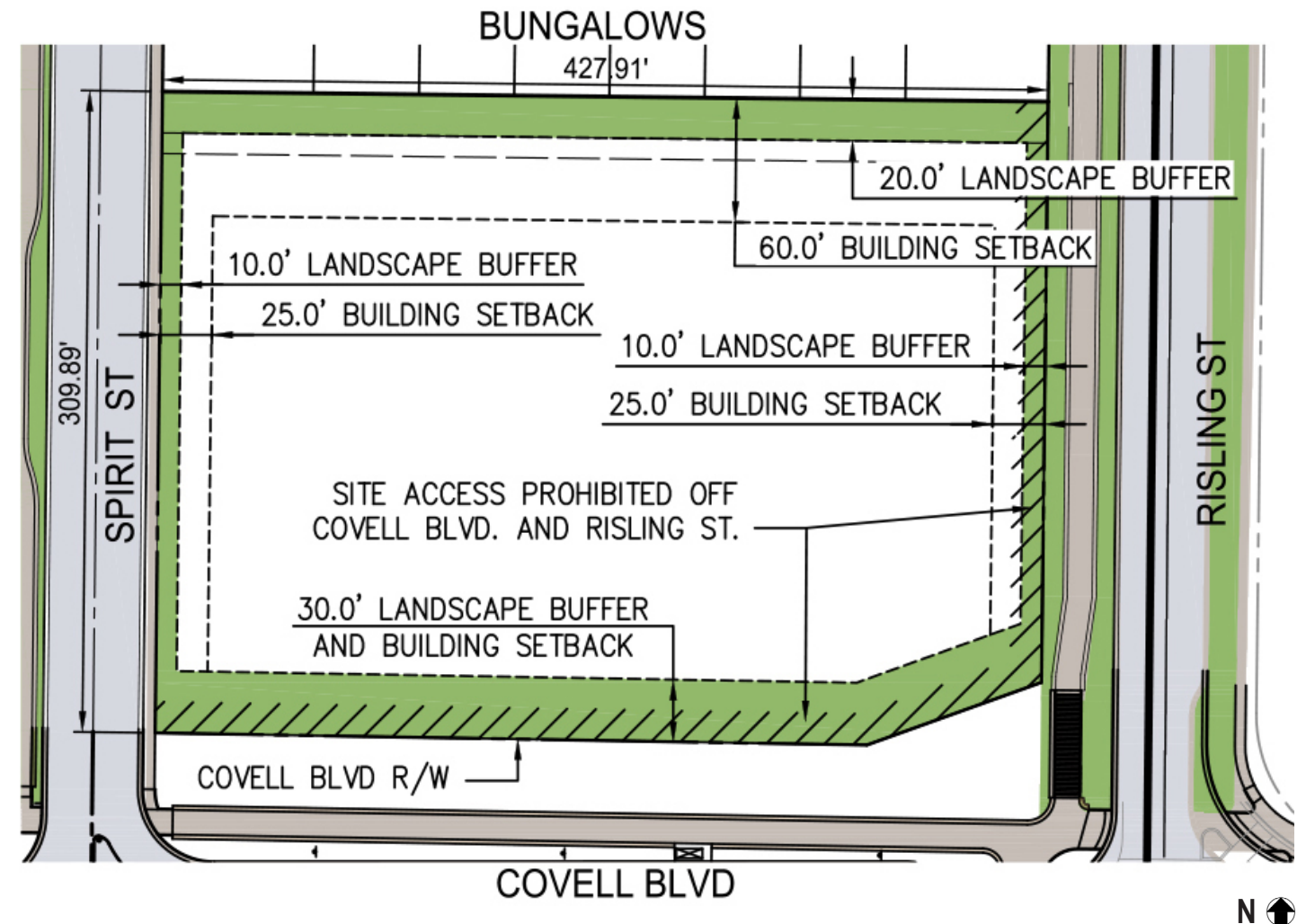

PARKING

- Group care homes: Minimum of two covered or uncovered spaces per unit.
- Supportive housing: Minimum of one covered or uncovered space per three beds. All parking requirements to be per City of Davis Municipal Code Chapter 40, Article 40.25.

Parking should be at the rear of multi-story buildings to provide additional separation between residential units. Parking is allowed to front Risling. No parking to front Covell Blvd.

Loading spaces required by Section 40.25.040 are not applicable to group care homes or supportive housing constructed on the site.

After completion, or parcel completion, of the residential neighborhoods included in Bretton Woods, should evidence demonstrate that, as a result of the adjacent hospital, development of the specialized senior care parcel, or for any other reason, neighborhood streets are being used for non-residential overflow parking on a reoccurring basis, the City agrees that, based on an application signed by the majority of residents on an affected neighborhood street(s), the City will process a request to add parking restrictions on the affected neighborhood street(s) to address such overflow parking.

Shading requirements for parking per the City of Davis Municipal Code.

For additional details, refer to Section 6.1. "Final Planned Development Table".

APPENDIX A: REFERENCES AND CONTACT INFORMATION

MASTER DEVELOPER

BRETTON WOODS, LLC
260 Russell Boulevard, Suite C
Davis, CA 95616
Phone: 530.231.5519



CIVIL ENGINEER & LANDSCAPE ARCHITECT

CUNNINGHAM ENGINEERING
2940 Spafford Street, Suite 200
Davis, CA 95618
Phone: 916.455.2026



ARCHITECTURAL CONSULTANT

BSB DESIGN, INC.
11211 Gold Country Boulevard, Suite 101
Gold River, CA 95670
Phone: 916.941.0990



APPENDIX B: PLANTING PALETTE

B.1. TREES

BOTANICAL	COMMON	CONTAINER	WATER USE	HxW	CA NATIVE	UCD ARBORETUM ALL STAR	POLLINATOR	CITY APPROVED TREES
ACER BUERGERIANUM	TRIDENT MAPLE	15 GAL	M	25'X25'			X	X
ACER TRUNCATUM X PLATANOIDES 'WARRENRED'	PACIFIC SUNSET MAPLE	15 GAL	M	30'X30'				X
ARBUTUS X 'MARINA'	ARBUTUS STANDARD	15 GAL	L	30'X30'		X	X	X
CEDRUS DEODARA	DEODAR CEDAR	15 GAL	L	50'X25'				X
CERCIS CANADENSIS	EASTERN REDBUD	15 GAL	M	25'X25'			X	
CERCIS OCCIDENTALIS	WESTERN REDBUD MULTI-TRUNK	15 GAL	L	10'X10'	X	X	X	
CHILOPSIS LINEARIS SSP. BUBBA	BUBBA DESERT WILLOW	15 GAL	L	20'X15'	X		X	
FRAXINUS VELUTINA 'RIO GRANDE'	VELVET ASH	15 GAL	M	35'X30'	X		X	
GYMNOCLADUS DIOICUS 'ESPRESSO-JFS'	ESPRESSO KENTUCKY COFFEE TREE	15 GAL	M	50'X35'				X
KOELREUTERIA BIPINNATA	CHINESE FLAME TREE	15 GAL	L	30'X30'			X	X
LAGERSTROEMIA X 'NATCHEZ'	CRAPE MYRTLE	15 GAL	L	20'X20'		X	X	X
MACLURA POMIFERA 'WHITE SHIELD'	WHITE SHIELD OSAGE-ORANGE	15 GAL	M	35'X35'				
PISTACIA CHINENSIS 'KEITH DAVEY'	KEITH DAVEY CHINESE PISTACHE	15 GAL	M	40'X30'				X
PODOCARPUS GRACILIOR 'COLUMN'	FERN PINE	15 GAL	L	12'X8'				
QUERCUS BUCKLEYI	TEXAS RED OAK	15 GAL	L	40'X40'				X
QUERCUS CANBYI	CANBY OAK	15 GAL	M	50'X40'				
QUERCUS ROBUR 'CRIMSCHMIDT'	CRIMSON SPIRE COLUMNAR OAK	15 GAL	M	35'X12'				
ULMUS 'FRONTIER'	FRONTIER ELM	15 GAL	M	40'X30'				X
ULMUS 'MORTON GLOSSY'	TRIUMPH ELM	15 GAL	M	50'X40'				
ZELKOVA SERRATA 'GREEN VASE'	GREEN VASE SAWLEAF ZELKOVA	15 GAL	M	60'X40'				X

B.2. OAK FOREST

BOTANICAL	COMMON	CONTAINER	WATER USE	HxW	CA NATIVE	UCD ARBORETUM ALL STAR	POLLINATOR	CITY APPROVED TREES
QUERCUS AGRIFOLIA	COAST LIVE OAK	15 GAL	L	40'X60'	X			X
QUERCUS DOUGLASII	BLUE OAK	15 GAL	L	60'X30'	X			X
QUERCUS LOBATA	VALLEY OAK	15 GAL	L	50'X50'	X	X	X	X

APPENDIX B: PLANTING PALETTE

B.3. FRUIT TREES FOR FRONT YARDS AT GREENWAYS

BOTANICAL	COMMON	CONTAINER	WATER USE	HxW	CA NATIVE	UCD ARBORETUM ALL STAR	POLLINATOR
CITRUS RETICULATA 'SATSUMA'	SATSUMA TANGERINE	15 GAL	M	20'X15'			X
CITRUS X AURANTIIFOLIA 'BEARSS SEEDLESS'	BEARSS SEEDLESS LIME	15 GAL	M	15'X15'			X
CITRUS X LIMON 'EUREKA'	EUREKA LEMON	15 GAL	M	15'X15'			X
CITRUS X PARADISI 'OROBLANCO'	OROBLANCO GRAPEFRUIT	15 GAL	M	20'X20'			X
CITRUS X SINENSIS 'VALENCIA'	SWEET ORANGE	15 GAL	M	20'X20'			X
PERSEA AMERICANA 'WURTZ'	WURTZ DWARF AVACADO	15 GAL	M	10'X10'			X
PRUNUS ARMENIACA 'BLENHEIM'	BLENHEIM APRICOT	15 GAL	M	15'X15'			X
PRUNUS AVIUM 'VANDALAY' SEMI-DWARF	SEMI-DWARF VANDALAY CHERRY	15 GAL	M	12'X12'			X
PRUNUS PERSICA NUCIPERSICA 'FANTASIA'	FANTASIA NECTARINE	15 GAL	M	12'X10'			X
PRUNUS PERSICA 'O'HENRY'	O'HENRY PEACH	15 GAL	M	15'X15'			X
PRUNUS SALICINA 'SANTA ROSA'	SANTA ROSA PLUM	15 GAL	M	12'X10'			X
PUNICA GRANATUM 'PARFIANKA'	PARFIANKA POMEGRANATE	15 GAL	M	10'X10'			X
PYRUS COMMUNIS 'BARTLETT'	BARTLETT PEAR	15 GAL	M	20'X10'			X

B.4. GROUNDCOVERS

BOTANICAL	COMMON	CONTAINER	WATER USE	HxW	CA NATIVE	UCD ARBORETUM ALL STAR	POLLINATOR
ACHILLEA MILLEFOLIUM 'ISLAND PINK'	ISLAND PINK YARROW	1 GAL	L	1'X5'	X	X	X
ARCTOSTAPHYLOS X 'EMERALD CARPET'	EMERALD CARPET MANZANITA	1 GAL	L	1'X5'	X		X
BACCHARIS PILULARIS	DWARF COYOTE BRUSH	5 GAL	L	2'X6'	X		X
CERATOSTIGMA PLUMBAGINOIDES	DWARF PLUMBAGO	1 GAL	L	1'X3'		X	X
CONVOLVULUS MAURITANICUS	MORNING GLORY	1 GAL	L	1'X3'	X		X
DELOSPERMA COOPERI	COOPER'S ICE PLANT	1 GAL	L	1'X2'		X	X
LONICERA HISPIDULA	CALIFORNIA HONEYSUCKLE	1 GAL	L	1'X5'	X		X
RIBES VIBURNIFOLIUM	EVERGREEN CURRANT	1 GAL	L	2'X6'	X	X	X
SALVIA X 'BEE'S BLISS'	SAGE	1 GAL	L	1.5'X6'	X		X
SALVIA SPATHACEA	HUMMINGBIRD SAGE	1 GAL	L	2'X6'	X	X	X
TEUCRIUM CHAMAEDRYS 'NANUM'	DWARF GERMANDER	1 GAL	L	1'X3'		X	X

B.5. ORNAMENTAL GRASSES

BOTANICAL	COMMON	CONTAINER	WATER USE	HxW	CA NATIVE	UCD ARBORETUM ALL STAR	POLLINATOR
MUHLENBERGIA CAPILLARIS	PINK MUHLY	1 GAL	L	3'X4'	X		X
MUHLENBERGIA RIGENS	DEERGRASS	1 GAL	L	4'X4'	X		X

APPENDIX B: PLANTING PALETTE

B.6. SHRUBS – LARGE

BOTANICAL	COMMON	CONTAINER	WATER USE	HxW	CA NATIVE	UCD ARBORETUM ALL STAR	POLLINATOR
ACACIA BOORMANII	SNOWY RIVER WATTLE	5 GAL	L	10'X10'		X	X
BACCHARIS SALICIFOLIA	MULE FAT	5 GAL	L	8'X6'	X		X
CALLISTEMON RUGULOSUS 'VIOLACEUS'	PURPLE BOTTLEBRUSH	5 GAL	L	6'X6'		X	X
CARPENTERIA CALIFORNICA 'ELIZABETH'	BUSH ANEMONE	5 GAL	L	5'X3'	X	X	X
CEANOTHUS 'RAY HARTMAN'	RAY HARTMAN CALIFORNIA LILAC	5 GAL	L	10'X10'	X	X	X
FRAUGALA CALIFORNICA	COFFEEBERRY	5 GAL	L	8'X8'	X		X
HETEROMELES ARBUTIFOLIA	TOYON	5 GAL	L	6'X6'	X	X	X
LATHYRUS JEPSONII VAR. CALIFORNICUS	CALIFORNIA PEA	5 GAL	L	7'X7'	X		X
OSMANTHUS X FORTUNEI	HYBRID TEA OLIVE	5 GAL	L	10'X8'		X	X
PHILADELPHUS 'BELLE ETOILE'	PURPLE SPOT MOCK ORANGE	5 GAL	L	6'X8'		X	X
RIBES MALVACEUM	CHAPARRAL CURRANT	5 GAL	L	5'X5'	X	X	X
ROSA CALIFORNICA	CALIFORNIA WILDROSE	5 GAL	L	8'X8'	X		X
RUBUS URSINUS	PACIFIC BLACKBERRY	5 GAL	L	6'X6'	X		X
SYRINGA LACINIATA	CUTLEAF LILAC	5 GAL	L	6'X6'	X	X	X

B.7. SHRUBS – MEDIUM

BOTANICAL	COMMON	CONTAINER	WATER USE	HxW	CA NATIVE	UCD ARBORETUM ALL STAR	POLLINATOR
ARCTOSTAPHYLOS DENSIFLORA 'HOWARD MCMINN'	VINE HILL MANZANITA	5 GAL	L	5'X5'	X	X	X
ASCLEPIAS FASCICULARIS	NARROW-LEAVED MILKWEED	1 GAL	L	3'X3'	X		X
CAREX PRAEGRACILIS	CLUSTERED FIELD SEDGE	1 GAL	L	3'X3'	X		X
CEANOTHUS 'CONCHA'	CONCHA CEANOTHUS	5 GAL	L	4'X4'	X	X	X
CEANOTHUS X PALLIDUS 'MARIE SIMON'	MARIE SIMON CEANOTHUS	5 GAL	L	5'X5'		X	X
DASYLIRION WHEELERI	DESERT SPOON	1 GAL	L	4'X4'		X	
DIETES VEGETA	AFRICAN IRIS	1 GAL	L	3'X3'			X
EPILOBIUM CANUM SSP. CANUM	CALIFORNIA FUCHSIA	1 GAL	L	3'X3'	X	X	X
ERIGONUM FASCICULATUM	CALIFORNIA BUCKWHEAT	1 GAL	L	4'X3'	X		X
ERIGONUM GIGANTEUM	SAINT CATHERINE'S LACE	1 GAL	L	4'X4'	X	X	X
GALVEZIA SPECIOSA 'FIRECRACKER'	BUSH SNAPDRAGON	1 GAL	L	3'X4'	X		X
ISOMERIS ARBOREA	BLADDERPOD	5 GAL	L	4'X4'	X	X	X
JUNCUS EFFUSUS	SOFT RUSH	1 GAL	L	4'X3'	X		X
LUPINUS ALBIFRONS	SILVER LUPINE	1 GAL	L	4'X5'	X		X
LEUCOPHYLLUM LANGMANIAE 'LYNN'S LEGACY'	LYNN'S LEGACY LEUCOPHYLLUM	5 GAL	L	4'X4'		X	X
LEUCOPHYLLUM FRUTESCENS	TEXAS RANGER	5 GAL	L	5'X5'		X	X

APPENDIX B: PLANTING PALETTE

B.7. SHRUBS – MEDIUM (CONTINUED)

BOTANICAL	COMMON	CONTAINER	WATER USE	HxW	CA NATIVE	UCD ARBORETUM ALL STAR	POLLINATOR
MAHONIA AQUIFOLIUM 'COMPACTA'	COMPACT OREGON GRAPE	5 GAL	L	3'X3'	X	X	X
MIMULUS AURANTIACUS	STICKY MONKEY FLOWER	1 GAL	L	4'X4'	X		X
MYRTUS COMMUNIS 'COMPACTA'	DWARF MYRTLE	5 GAL	L	4'X4'			X
PHLOMIS PURPEREA	PINK PHLOMIS	1 GAL	L	4'X4'		X	X
RHAMNUS CALIFORNICA 'EVE CASE'	EVE CASE COFFEBERRY	5 GAL	L	4'X4'	X		
RIBES MALVACEUM	CHAPARRAL CURRANT	1 GAL	L	5'X5'	X	X	X
ROSA 'PINK GRUSS AN AACHEN'	GRUSS AN AACHEN FLORIBUNDA ROSE	5 GAL	L	4'X4'		X	X
ROSA X ODORATA 'MUTABILLS'	BUTTERFLY ROSE	5 GAL	L	5'X5'		X	X
ROSMARINUS OFFICINALIS 'MOZART'	ED CARMAN'S ROSEMARY	1 GAL	L	3'X3'		X	X
SAGITTARIA SANFORDII	SANFORD'S ARROWHEAD	1 GAL	L	3'X3'	X		X
SALVIA APIANA	CALIFORNIA WHITE SAGE	5 GAL	L	4'X4'	X	X	X
SALVIA CELESTIAL BLUE	PURPLE SAGE	5 GAL	L	4'X4'	X		X
SALVIA CLEVELANDII 'WINNIFRED GILMAN'	WINNIFRED GILMAN CLEVELAND SAGE	5 GAL	L	4'X4'	X	X	X
SOLIDAGO CALIFORNICA 'CASCADE CREEK'	CASCADE CREEK CALIFORNIA GOLDENROD	1 GAL	L	3'X3'	X	X	X
SYMPHORICARPOS ALBUS	COMMON SNOWBERRY	5 GAL	L	4'X6'	X		X
TEUCRIUM FRUTICANS	BUSH GERMANDER	5 GAL	L	4'X4'	X	X	X

B.8. SHRUBS – SMALL

BOTANICAL	COMMON	CONTAINER	WATER USE	HxW	CA NATIVE	UCD ARBORETUM ALL STAR	POLLINATOR
CEANOTHUS MARITIMUS 'VALLEY VIOLET'	MARITIME CEANOTHUS	1 GAL	L	2'X4'	X	X	X
DICHELOSTEMMA CAPITATUM	BLUE DICKS	1 GAL	L	2'X2'	X		X
ESCHSCHOLZIA CALIFORNICA	CALIFORNIA POPPY	1 GAL	L	2'X2'	X		X
HESPERALOE PARVIFLORA 'BRAKELIGHTS'™	BRAKELIGHTS RED YUCCA	1 GAL	L	2'X2'		X	X
LASTHENIA GLABRATA	YELLOW RAYED LASTHENIA	1 GAL	L	2'X2'	X		X
LAVANDULA X GINGINSII 'GOODWIN CREEK GREY'	GOODWIN CREEK LAVENDER	1 GAL	L	2'X2'		X	X
LAVANDULA STOECHAS 'OTTO QUAST'	SPANISH LAVENDER	1 GAL	L	2'X3'		X	X
LUPINUS FORMOSUS	SUMMER LUPINE	1 GAL	L	2'X2'	X		X
PENSTEMON HETEROPHYLLUS 'MARGARITA BOP'	BEARD TONGUE	1 GAL	L	2'X3'	X	X	X
SALVIA 'DARA'S CHOICE'	DARA'S CHOISE CREEPING SAGE	1 GAL	L	2'X3'	X		X
SALVIA X JAMENSIS	AUTUMN SAGE	1 GAL	L	2'X3'		X	X
SALVIA NUMZII 'EMERALD CASCADE'	EMERALD CASCADE SAGE	1 GAL	L	2'X3'	X		X
SISYRINCHIUM BELLUM	BLUE EYED GRASS	1 GAL	L	1'X3'	X		X

APPENDIX B: PLANTING PALETTE

B.8. SHRUBS – SMALL (CONTINUED)

BOTANICAL	COMMON	CONTAINER	WATER USE	HxW	CA NATIVE	UCD ARBORETUM ALL STAR	POLLINATOR
VERBENA CANADENSIS 'HOMESTEAD PURPLE'	HOMESTEAD PURPLE VERBENA	1 GAL	L	12"X18"	X		X
VIGUIERA PARISHII	DESERT GOLDENEYE	1 GAL	L	2'X2'	X	X	X

B.9. VINES

BOTANICAL	COMMON	CONTAINER	WATER USE	HxW	CA NATIVE	UCD ARBORETUM ALL STAR	POLLINATOR
HARDENBERGIA VIOLACEA	LILAC VINE	1 GAL	L	12'X5'		X	X
JASMINUM NUDIFLORUM	WINTER JASMINE	1 GAL	L	12'X5'		X	X
LONICERA HISPIDULA VAR. VACILLANS	CALIFORNIA HONEYSUCKLE	1 GAL	L	5'X10'	X		X
ROSA CLIMBING ROSE 'GOLDEN SHOWERS'	'GOLDEN SHOWERS'	5 GAL	M	6'X8'			X

B.10. ROSES

BOTANICAL	COMMON	CONTAINER	WATER USE	HxW	CA NATIVE	UCD ARBORETUM ALL STAR	POLLINATOR
ROSA FLORIBUNDA 'JULIA CHILDS'	JULIA CHILDS ROSE	5 GAL	M	5'X3'			X
ROSA HYBRID TEA ROSE 'MISTER LINCOLN' TM	MISTER LINCOLN TEA ROSE	5 GAL	M	5'X3'			X
ROSA HYBRID TEA ROSE 'STAINLESS STEEL'	STAINLESS STEEL TEA ROSE	5 GAL	M	5'X4'			X
ROSA STANDARD X 'EASY DOES IT'	EASY DOES IT ROSE	2 GAL	M	4'X3'			X
ROSA 'KRICARLO'	TOUCH OF CLASS	2 GAL	M	4'X4'			X

B.11. GROUND PLANE

BOTANICAL	COMMON	CONTAINER	WATER USE	HxW	CA NATIVE	UCD ARBORETUM ALL STAR	POLLINATOR
NON-IRRIGATED HYDROSEED MIX, PACIFIC COAST SEED	HERITAGE MIX 40 LBS. / ACRE	HYDROSEED	L		X		
NO MOW FESCUE		SOD	M				
TURF SOD	DROUGHT TOLERANT FESCUE BLEND	SOD	H				

TOTALS (*): 64% CA NATIVE; 50% UCD ALL STARS

*Percentage of California Native and UC Davis Arboretum All-Stars shown are based on the total of ground covers, grasses, shrubs, vines, roses and ground plane plantings. Tree species are not included in the quantity.



Bretton Woods